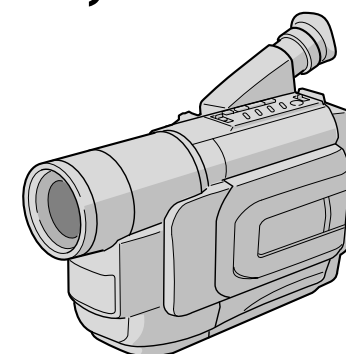

SERVICE MANUAL

COMPACT VHS CAMCORDER

GR-FXM38EG/EK, SXM48EG/EK/EA
SXM67ED, SXM87ED
S-VHS VHS
PAL
625

Super VHS
Super VHS ET

SPECIFICATIONS (The specifications shown pertain specifically to the model GR-SXM58EK/SXM48EK/FXM38EK/SX24EK/FX14EK)

Camcorder	
General	
Format	: S-VHS (GR-SXM58/SXM48/SX24 only)/VHS PAL standard
Power source	: DC 11 V \equiv (Using AC Adapter) DC 6 V \equiv (Using battery pack)
Power consumption	
Viewfinder on	: 4.0 W (GR-SXM58/SXM48/FXM38 only) 3.7 W (GR-SX24/FX14 only)
LCD monitor* on	: 4.5 W (GR-SXM58/SXM48/FXM38 only)
Video light**	: 3.0 W
* Applicable models only. ** GR-SXM58/SXM48/SX24 only.	
Signal system	: PAL-type
Video recording system	
Luminance	: FM recording
Colour	: Converted sub-carrier direct recording Conforms to VHS standard
Cassette	: S-VHS / VHS cassette
Tape speed	
SP	: 23.39 mm/sec.
LP	: 11.70 mm/sec.
Recording time (max.)	
SP	: 60 minutes
LP	: 120 minutes (with EC-60 cassette)
Operating temperature	: 0°C to 40°C
Operating humidity	: 35% to 80%
Storage temperature	: -20°C to 50°C
Weight	: Approx. 910 g (GR-SXM58/SXM48 only) Approx. 900 g (GR-FXM38 only) Approx. 860 g (GR-SX24 only) Approx. 850 g (GR-FX14 only)
Dimensions	: 200 mm x 112 mm x 118 mm (GR-SXM58/SXM48/FXM38 only) 200 mm x 112 mm x 115 mm (GR-SX24/FX14 only) (with the LCD monitor* closed and with the viewfinder fully tilted downward)
* Applicable models only.	
Pickup	: 1/6" format CCD
Lens	: F1.6, f = 3.9 mm to 62.4 mm, 16:1 power zoom lens with auto iris and macro control, filter diameter 40.5 mm
Viewfinder	: Electronic viewfinder with 0.5" black/white CRT
White balance adjustment	: Auto/Manual adjustment
LCD monitor	: 2.5" diagonally measured, LCD panel/TFT
(Applicable models only)	: active matrix system
Speaker	: Monaural
(Applicable models only)	
Connectors	
Video (via Video output connector)	: 1 V (p-p), 75 Ω unbalanced, analogue output
Audio (via Audio output connector)	: 300 mV (rms), 1 kW analogue output
Digital	: ϕ 3.5 mm, 4-pole, mini-head jack
(GR-SXM58 only)	
S-Video	: Y : 1 V (p-p), 75 Ω , analogue output
(GR-SXM58/SXM48/SX24 only)	: C : 0.30 V (p-p), 75 Ω , analogue output
AC Adapter	
Power requirement	: AC 110 V — 240 V \sim , 50 Hz/60 Hz
Output	: DC 11 V \equiv , 1 A
Optional Accessories	
<ul style="list-style-type: none"> • Battery Packs BN-V12U, BN-V20U, BN-V400U • Compact S-VHS (S-VHS) Cassettes SE-C45/30 • Compact VHS (VHS) Cassettes EC-60/45/30 • Active Carrying Bag CB-V7U • Cassette Adapter C-P7U 	
Some accessories are not available in some areas. Please consult your nearest JVC dealer for details on accessories and their availability.	
Specifications shown are for SP mode unless otherwise indicated. E & O.E. Design and specifications subject to change without notice.	

GR-FXM38EG/EK, SXM48EG/EK/EA, SXM67ED, SXM87ED

No. 86655

JVC

VICTOR COMPANY OF JAPAN, LIMITED
VIDEO DIVISION

S40894

TABLE OF CONTENTS

Section	Title	Page	Section	Title	Page
Important Safety Precautions			4. CHARTS AND DIAGRAMS		
INSTRUCTIONS			NOTES OF SCHEMATIC DIAGRAM 4-1		
1. DISASSEMBLY			CIRCUIT BOARD NOTES 4-2		
1.1	SERVICE CAUTIONS	1-1	4.1	BOARD INTERCONNECTIONS	4-3
1.1.1	Precautions	1-1	4.2	CPU SCHEMATIC DIAGRAM	4-5
1.1.2	How to read the disassembly and assembly	1-1	4.3	M.MDA SCHEMATIC DIAGRAM	4-7
1.1.3	Connection of the wires	1-1	4.4	VTR ASP SCHEMATIC DIAGRAM	4-9
1.2	TOOLS REQUIRED FOR ADJUSTMENTS	1-2	4.5	DSP SCHEMATIC DIAGRAM	4-11
1.3	DISASSEMBLY/ASSEMBLY OF CABINET PARTS	1-3	4.6	F/Z//MDA SCHEMATIC DIAGRAM	4-13
1.3.1	Disassembly flow chart	1-3	4.7	V OUT SCHEMATIC DIAGRAM	4-15
1.3.2	Disassembly method	1-4	4.8	TG/CDS SCHEMATIC DIAGRAM	4-17
1.4	DISASSEMBLY/ASSEMBLY OF CAMERA SECTION AND DECK SECTION	1-10	4.9	REG SCHEMATIC DIAGRAM	4-19
1.4.1	Flowchart of disassembly	1-10	4.10	LCD/CVF SCHEMATIC DIAGRAM	4-21
1.4.2	Disassembly method	1-10	4.11	BW/CVF SCHEMATIC DIAGRAM	4-23
1.5	REPLACEMENT OF CCD IMAGE SENSOR	1-12	4.12	JACK SCHEMATIC DIAGRAM	4-25
1.5.1	Removal of CCD image sensor	1-12	4.13	SPEAKER SCHEMATIC DIAGRAM	4-27
1.5.2	Installation of new CCD image sensor	1-12	4.14	CCD SCHEMATIC DIAGRAM	4-28
1.5.3	Replacement of CCD board assy	1-12	4.15	MONITOR SCHEMATIC DIAGRAM	4-29
1.6	TAKE OUT CASSETTE TAPE	1-13	4.16	E. VF SCHEMATIC DIAGRAM	4-31
1.7	EMERGENCY DISPLAY	1-14	4.17	TOP OPE UNIT, ZOOM UNIT, REAR UNIT AND SENSOR SCHEMATIC DIAGRAMS	4-33
1.8	DEMONSTRATION MODE	1-14	4.18	MAIN CIRCUIT BOARD	4-35
1.9	SERVICE NOTE	1-16	4.19	MONITOR CIRCUIT BOARD	4-41
2. MECHANISM ADJUSTMENT			4.20	CCD CIRCUIT BOARD	4-43
2.1	SERVICE CAUTIONS	2-1	4.21	E. VF CIRCUIT BOARD	4-44
2.1.1	Precautions	2-1	4.22	WAVEFORMS	4-45
2.1.2	How to read the disassembly and assembly (For Mechanism Parts)	2-1	4.23	VOLTAGE CHARTS	4-46
2.1.3	Required adjustment tools	2-1	4.24	POWER SYSTEM BLOCK DIAGRAM	4-51
2.2	DISASSEMBLY/ASSEMBLY OF MECHANISM PARTS	2-2	4.25	CPU/MDA SYSTEM BLOCK DIAGRAM	4-53
2.3	CHECKUP AND ADJUSTMENT OF MECHANISM PHASE	2-6	4.26	CAMERA AND Y/C SYSTEM BLOCK DIAGRAM	4-55
2.4	TAPE TRANSPORT ADJUSTMENT	2-7	4.27	MONITOR SYSTEM BLOCK DIAGRAM	4-59
2.4.1	Back tension	2-7	5. PARTS LIST		
2.4.2	Tape pattern	2-7	5.1	PACKING AND ACCESSORY ASSEMBLY <M1>	5-1
2.4.3	A/C head height & azimuth	2-8	5.2	FINAL ASSEMBLY <M2>	5-3
2.4.4	Phase of control head (X value)	2-9	5.3	MECHANISM ASSEMBLY <M3>	5-6
2.5	REMARKS	2-9	5.4	ELECTRONIC VIEWFINDER ASSEMBLY <M4>	5-8
2.5.1	Cleaning	2-9	5.5	MONITOR ASSEMBLY <M5>	5-9
2.5.2	Applying oil and grease	2-9	5.6	ELECTRICAL PARTS LIST	5-10
2.5.3	Checkup	2-9		MAIN BOARD ASSEMBLY <01>	5-10
2.6	JIG CONNECTOR CABLE CONNECTION	2-10		CCD BOARD ASSEMBLY <02>	5-16
3. ELECTRICAL ADJUSTMENT				MONITOR BOARD ASSEMBLY <07>	5-16
3.1	ELECTRICAL ADJUSTMENT	3-1		E.VF BOARD ASSEMBLY <60>	5-17
3.1.1	PREPARATION	3-1	3.1.1 PREPARATION		
3.2	ELECTRONIC VIEWFINDER (E. VF) ADJUSTMENT	3-2	3.2 ELECTRONIC VIEWFINDER (E. VF) ADJUSTMENT		
3.2.1	Tilt	3-2	3.2.1 Tilt		
3.2.2	Centering	3-2	3.2.2 Centering		
3.2.3	Vertical scanning	3-2	3.2.3 Vertical scanning		
3.2.4	Brightness	3-2	3.2.4 Brightness		
3.2.5	Focus	3-2	3.2.5 Focus		

The following table lists the differing points between Models GR-FXM38EG, GR-FXM38EK, GR-SXM48EG, GR-SXM48EK, GR-SXM48EA, GR-SXM67ED and GR-SXM87ED in this serise.

	GR-FXM38EG	GR-FXM38EK	GR-SXM48EG	GR-SXM48EK	GR-SXM48EA	GR-SXM67ED	GR-SXM87ED
TAPE FORMAT	VHS-C	VHS-C	S-VHS-C	S-VHS-C	S-VHS-C	S-VHS-C	S-VHS-C
S-VHS ET	NOT USED	NOT USED	USED	USED	USED	USED	USED
VIDEO LIGHT	NOT USED	NOT USED	USED	USED	USED	NOT USED	USED
IR RECIVER	NOT USED	NOT USED	NOT USED	NOT USED	NOT USED	NOT USED	USED
SNAP SHOT	NOT USED	NOT USED	USED	USED	USED	NOT USED	USED
NIGHT ALIVE(SCOPE)	NOT USED	NOT USED	USED	USED	USED	NOT USED	USED
5 SEC REC	USED	USED	NOT USED	NOT USED	NOT USED	USED	NOT USED
S OUTPUT	NOT USED	NOT USED	USED	USED	USED	USED	USED
EDIT CTL OUTPUT	NOT USED	NOT USED	NOT USED	NOT USED	NOT USED	NOT USED	USED
AC ADAPTER	AP-V12EG	AP-V12EG	AP-V12EG	AP-V12EG	AP-V12EG	AP-V12ED	AP-V12ED
BATTERY PACK	BN-V11U-E	BN-V11U-E	BN-V11U-E	BN-V11U-E	BN-V20BU	BN-V20BU	BN-V20BU
REMOTE CONTROL UNIT	NOT USED	NOT USED	NOT USED	NOT USED	NOT USED	NOT USED	PROVIDE
S VIDEO CABLE	NOT USED	NOT USED	PROVIDE	PROVIDE	OPTIONAL	OPTIONAL	OPTIONAL
CASSETTE ADAPTER	NOT USED	NOT USED	OPTIONAL	OPTIONAL	PROVIDE	PROVIDE	PROVIDE
CABLE ADAPTER	USED(W/S TERMINAL)	USED(W/S TERMINAL)	USED(W/S TERMINAL)	USED(W/S TERMINAL)	NOT USED	NOT USED	NOT USED

Important Safety Precautions

Prior to shipment from the factory, JVC products are strictly inspected to conform with the recognized product safety and electrical codes of the countries in which they are to be sold. However, in order to maintain such compliance, it is equally important to implement the following precautions when a set is being serviced.

● Precautions during Servicing

1. Locations requiring special caution are denoted by labels and inscriptions on the cabinet, chassis and certain parts of the product. When performing service, be sure to read and comply with these and other cautionary notices appearing in the operation and service manuals.

2. Parts identified by the \triangle symbol and shaded () parts are critical for safety.

Replace only with specified part numbers.

Note: Parts in this category also include those specified to comply with X-ray emission standards for products using cathode ray tubes and those specified for compliance with various regulations regarding spurious radiation emission.

3. Fuse replacement caution notice.
Caution for continued protection against fire hazard.
Replace only with same type and rated fuse(s) as specified.

4. Use specified internal wiring. Note especially:

- 1) Wires covered with PVC tubing
- 2) Double insulated wires
- 3) High voltage leads

5. Use specified insulating materials for hazardous live parts. Note especially:

- | | | |
|--------------------|--------------------------------------|------------|
| 1) Insulation Tape | 3) Spacers | 5) Barrier |
| 2) PVC tubing | 4) Insulation sheets for transistors | |

6. When replacing AC primary side components (transformers, power cords, noise blocking capacitors, etc.) wrap ends of wires securely about the terminals before soldering.

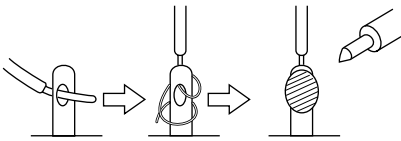

Fig.1

7. Observe that wires do not contact heat producing parts (heatsinks, oxide metal film resistors, fusible resistors, etc.)

8. Check that replaced wires do not contact sharp edged or pointed parts.

9. When a power cord has been replaced, check that 10-15 kg of force in any direction will not loosen it.

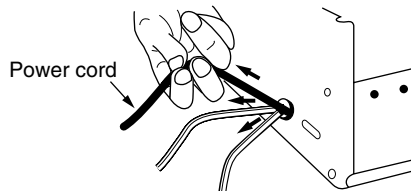

Fig.2

10. Also check areas surrounding repaired locations.

11. Products using cathode ray tubes (CRTs)
In regard to such products, the cathode ray tubes themselves, the high voltage circuits, and related circuits are specified for compliance with recognized codes pertaining to X-ray emission. Consequently, when servicing these products, replace the cathode ray tubes and other parts with only the specified parts. Under no circumstances attempt to modify these circuits. Unauthorized modification can increase the high voltage value and cause X-ray emission from the cathode ray tube.

12. Crimp type wire connector

In such cases as when replacing the power transformer in sets where the connections between the power cord and power transformer primary lead wires are performed using crimp type connectors, if replacing the connectors is unavoidable, in order to prevent safety hazards, perform carefully and precisely according to the following steps.

1) Connector part number : E03830-001

2) Required tool : Connector crimping tool of the proper type which will not damage insulated parts.

3) Replacement procedure

(1) Remove the old connector by cutting the wires at a point close to the connector.

Important : Do not reuse a connector (discard it).

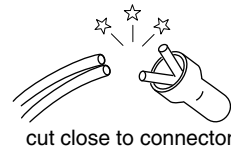

Fig.3

(2) Strip about 15 mm of the insulation from the ends of the wires. If the wires are stranded, twist the strands to avoid frayed conductors.

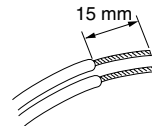

Fig.4

(3) Align the lengths of the wires to be connected. Insert the wires fully into the connector.

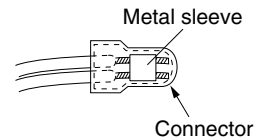

Fig.5

(4) As shown in Fig.6, use the crimping tool to crimp the metal sleeve at the center position. Be sure to crimp fully to the complete closure of the tool.

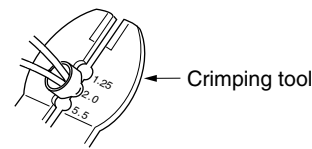

Fig.6

(5) Check the four points noted in Fig.7.

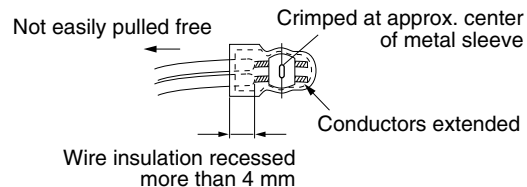

Fig.7

● Safety Check after Servicing

Examine the area surrounding the repaired location for damage or deterioration. Observe that screws, parts and wires have been returned to original positions. Afterwards, perform the following tests and confirm the specified values in order to verify compliance with safety standards.

1. Insulation resistance test

Confirm the specified insulation resistance or greater between power cord plug prongs and externally exposed parts of the set (RF terminals, antenna terminals, video and audio input and output terminals, microphone jacks, earphone jacks, etc.). See table 1 below.

2. Dielectric strength test

Confirm specified dielectric strength or greater between power cord plug prongs and exposed accessible parts of the set (RF terminals, antenna terminals, video and audio input and output terminals, microphone jacks, earphone jacks, etc.). See table 1 below.

3. Clearance distance

When replacing primary circuit components, confirm specified clearance distance (d), (d') between soldered terminals, and between terminals and surrounding metallic parts. See table 1 below.

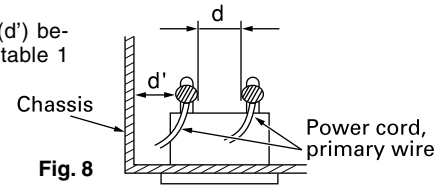

4. Leakage current test

Confirm specified or lower leakage current between earth ground/power cord plug prongs and externally exposed accessible parts (RF terminals, antenna terminals, video and audio input and output terminals, microphone jacks, earphone jacks, etc.).

Measuring Method : (Power ON)

Insert load Z between earth ground/power cord plug prongs and externally exposed accessible parts. Use an AC voltmeter to measure across both terminals of load Z. See figure 9 and following table 2.

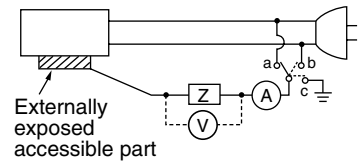

Fig. 9

5. Grounding (Class 1 model only)

Confirm specified or lower grounding impedance between earth pin in AC inlet and externally exposed accessible parts (Video in, Video out, Audio in, Audio out or Fixing screw etc.).

Measuring Method:

Connect milli ohm meter between earth pin in AC inlet and exposed accessible parts. See figure 10 and grounding specifications.

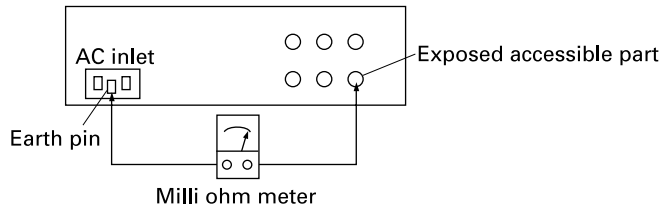

Fig. 10

Grounding Specifications

Region	Grounding Impedance (Z)
USA & Canada	$Z \leq 0.1 \text{ ohm}$
Europe & Australia	$Z \leq 0.5 \text{ ohm}$

AC Line Voltage	Region	Insulation Resistance (R)	Dielectric Strength	Clearance Distance (d), (d')
100 V	Japan	$R \geq 1 \text{ M}\Omega/500 \text{ V DC}$	AC 1 kV 1 minute	$d, d' \geq 3 \text{ mm}$
100 to 240 V			AC 1.5 kV 1 minute	$d, d' \geq 4 \text{ mm}$
110 to 130 V	USA & Canada	$1 \text{ M}\Omega \leq R \leq 12 \text{ M}\Omega/500 \text{ V DC}$	AC 1 kV 1 minute	$d, d' \geq 3.2 \text{ mm}$
110 to 130 V 200 to 240 V	Europe & Australia	$R \geq 10 \text{ M}\Omega/500 \text{ V DC}$	AC 3 kV 1 minute (Class II) AC 1.5 kV 1 minute (Class I)	$d \geq 4 \text{ mm}$ $d' \geq 8 \text{ mm}$ (Power cord) $d' \geq 6 \text{ mm}$ (Primary wire)

Table 1 Specifications for each region

AC Line Voltage	Region	Load Z	Leakage Current (i)	a, b, c
100 V	Japan		$i \leq 1 \text{ mA rms}$	Exposed accessible parts
110 to 130 V	USA & Canada		$i \leq 0.5 \text{ mA rms}$	Exposed accessible parts
110 to 130 V 220 to 240 V	Europe & Australia		$i \leq 0.7 \text{ mA peak}$ $i \leq 2 \text{ mA dc}$	Antenna earth terminals
			$i \leq 0.7 \text{ mA peak}$ $i \leq 2 \text{ mA dc}$	Other terminals

Table 2 Leakage current specifications for each region

Note: These tables are unofficial and for reference only. Be sure to confirm the precise values for your particular country and locality.

SECTION 1 DISASSEMBLY

1.1 SERVICE CAUTIONS

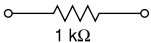
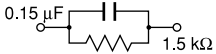
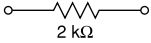
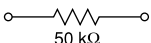
1.1.1 Precautions

1. Before disassembling/re-assembling the set as well as soldering parts, make sure to disconnect the power cable.
2. When disconnecting/connecting connectors, pay enough attention to wiring not to damage it.
3. In general, chip parts such as resistor, shorting jumpers (0-ohm resistor), ceramic capacitors, diodes, etc. can not be reused after they were once removed.
4. When installing parts, be careful not to do with other parts as well as not to damage others.
5. When removing ICs, be careful not to damage circuit patterns.
6. Tighten screws properly during the procedures. Unless specified otherwise, tighten screws at torque of 0.196 N•m (2.0 kgf•cm).

1.1.2 How to read the disassembly and assembly

(For Cabinet Parts)

STEP No.	PART	Fig. No.	REMOVAL
			*UNLOCK/RELEASE/ UNPLUG/UNCLAMP/ UNSOLDER
①	CASSETTE COVER ASSEMBLY	C1	2(S①)
②	UPPER CASE	C2	2(S②), 2(L②)
③	LOWER CASE ASSEMBLY (Incl. E.VF ASSEMBLY)	C3	9(S③), (L③a), (L③b) *CN③a, CN③b, COVER(JACK)

(1) (2) (3) (4)

- (1) Order of steps in Procedure
When reassembling, preform the step(s) in the reverse order. These numbers are also used as the identification (location) No. of parts Figures.
- (2) Part to be removed or installed.
- (3) Fig. No. showing Procedure or Part Location.
C = Cabinet
CA = Camera
D = Deck
- (4) Identification of part to be removed, unhooked, unlocked, released, unplugged, unclamped or unsoldered.
P = Spring
W = Washer
S = Screw
* = Unhook, unlock, release, unplug or unsolder.
2(S③) = 2 Screws (S③)
CN = Connector
- (5) Adjustment information for installation.

1.1.3 Connection of the wires

1. Pull the connector structure upward to release the clamp when removing or inserting the flat wire cable.

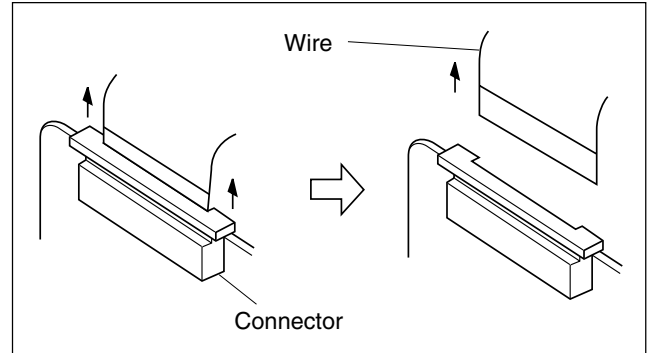

Fig. 1-1-1

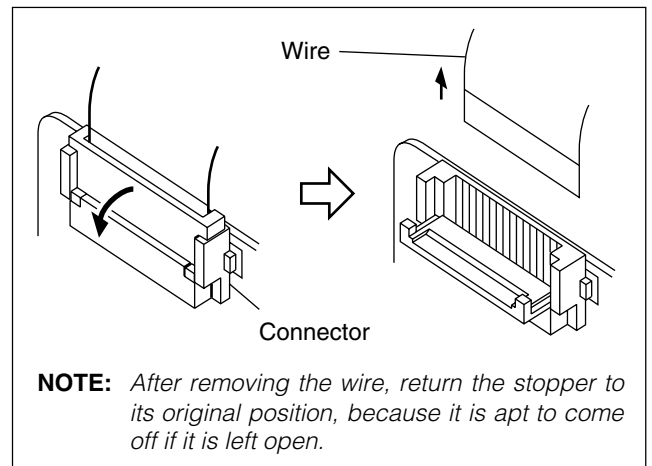
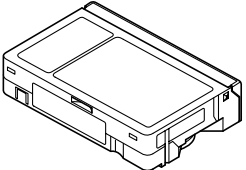
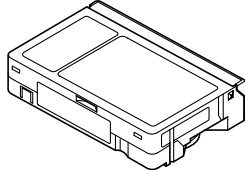
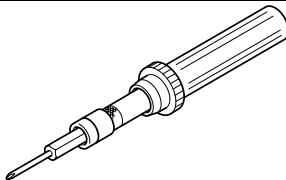
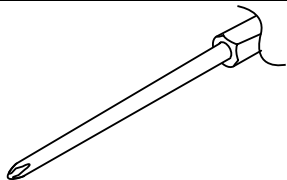
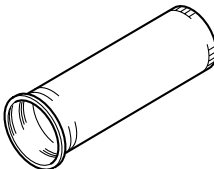
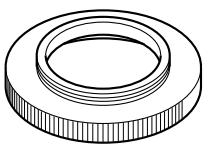
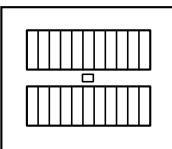
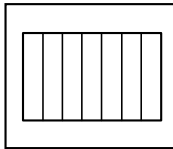
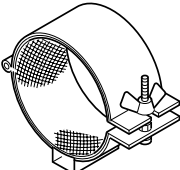
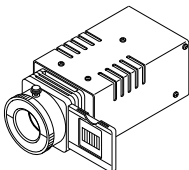
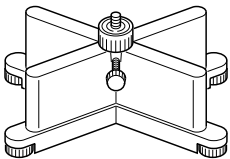

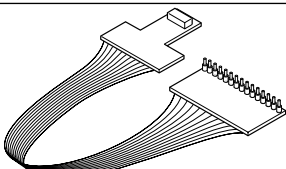
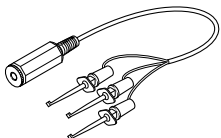

Fig. 1-1-2

1.2 TOOLS REQUIRED FOR ADJUSTMENTS

1	Alignment tape (for SP interchangeability) MHPE-C	2	Alignment tape (for N. SP PB Y/C level) MHVE-2C
			
3	Torque driver YTU94088	4	Bit YTU94088-003
			
5	INF adjustment lens YTU92001B	6	Conn. ring YTU92001-111
			
7	Gray Scale Chart YTU94133A	8	Color Bar Chart YTU94133C
			
9	INF lens holder YTU94087	10	Light box Assembly YTU93096A
			
11	Camera stand YTU93079	12	Extension connector YTU94145B-30
			
13	Jig connector cable YTU93106A	14	Communication cable YTU93107A
			

15	Service support system YTU94057-56	16	PC cable QAM0099-002
			
17	Cleaning cloth KSMM-01		
			

Table 1-2-1

1,2. Alignment tape

To be used for check and adjustment of interchangeability of the mechanism.
(Video: Color bar signal, Audio: Non-signal)

3. Torque driver

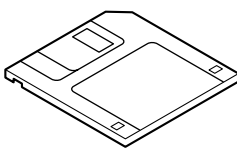
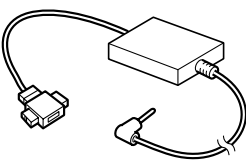
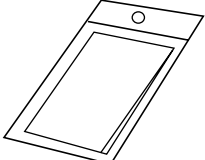
Be sure to use to fastening the mechanism and exterior parts because those parts must strictly be controlled for tightening torque.

4. Bit

This bit is slightly longer than those set in conventional torque drivers.

5. INF adjustment lens

To be used for adjustment of the camera system.

6. Conn. ring

The connector ring to attach the INF. lens to the head of the OP lens.

7. Gray scale chart

To be used for adjustment of the camera system.

8. Color bar chart

To be used for adjustment of the camera system.

9. INF lens holder

To be used together with the camera stand (11) for operating the VideoMovie in the stripped-down condition such as the status without the exterior parts or for using commodities that are not yet conformable to the interchangeable ring.

10. Light box assembly

To be used for adjustment of the camera system.

11. Camera stand

To be used together with the INF adjustment lens holder.

12. Extention connector

To be used to JIG connector cable

13. JIG connector cable

Connected to CN25 of the main board and used for measuring error rates, etc.

14. Communication Cable

Connect the Communication cable between the PC cable and Jig connector cable when performing a PC adjustment.

15. Service support system

To be used for adjustment with a personal computer.

16. PC cable

To be used to connect the VideoMovie and a personal computer with each other when a personal computer is used for adjustment.

17. Cleaning cloth

Recommended cleaning cloth to wipe down the video heads, mechanism (tape transport system), optical lens surface.

1.3 DISASSEMBLY/ASSEMBLY OF CABINET PARTS

1.3.1 Disassembly flow chart

This flowchart indicates the disassembly step for the cabinet parts and board assembly in order to gain access to item(s) to be serviced. When reassembling, perform the step(s) in reverse order. Bend, route and dress the flat cables as they were originally.

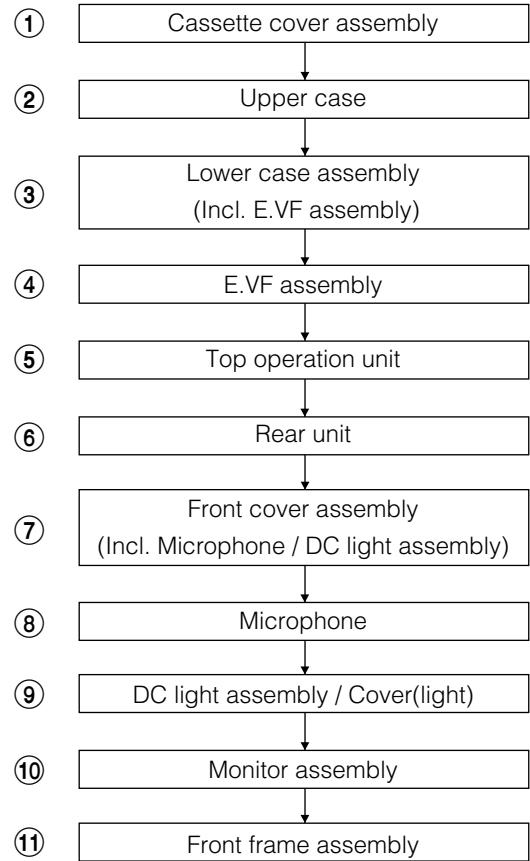

NOTE : For screw management, refer to the table appearing in the section "1.9 SERVICE NOTE" (page 1-16).

1.3.2 Disassembly method

STEP /LOC No.	PART	Fig. No.	REMOVAL
			*UNLOCK/RELEASE/ UNPLUG/UNCLAMP/ UNSOLDER
①	CASSETTE COVER ASSEMBLY	C1	2(S①)
②	UPPER CASE	C2	2(S②), 2(L②)
③	LOWER CASE ASSEMBLY (Incl. E.VF ASSEMBLY)	C3	9(S③), (L③a), (L③b) *CN③a, CN③b, COVER(JACK)
④	E.VF ASSEMBLY	C4	3(S④)
⑤	TOP OPERATION UNIT	C5	2(S⑤), (L⑤a), (L⑤b), 2(L⑤c), *CN⑤a
⑥	REAR UNIT	C6	3(S⑥), (L⑥a), (L⑥b), *CN⑥a
⑦	FRONT COVER ASSEMBLY (Incl. MICROPHONE / DC LIGHT ASSEMBLY)	C7	2(S⑦a), (S⑦b), (L⑦a), (L⑦b), *CN⑦a
⑧	MICROPHONE		(S⑦a)
⑨	DC LIGHT ASSEMBLY COVER (LIGHT)		2(L⑦c)
⑩	MONITOR ASSEMBLY	C8	2(S⑧a), (S⑧b), *CN⑧a
		C9	2(S⑨a), (S⑨b), (S⑨c)
		C10	2(S⑩a), 2(S⑩b), 2(S⑩c), (L⑩a), (L⑩b), (L⑩c)
		C11	(S⑪), (L⑪a), *CN⑪a, CN⑪b
		C12	2(S⑫a), (S⑫b), 2(L⑫a)
⑪	FRONT FRAME ASSEMBLY	C13	2(S⑬)

List of Abbreviations:

- 2(S①)=2 screws (S①)
- 4(L①a)=4 Locking Tabs
- CN=Connector

Reference Notes:

<NOTE 1>

Destination of connectors

Note : Two kinds of double-arrows in connection tables respectively show kinds of connector/wires.

- ↔ : Flat wire
- ⇔ : Wire

Con- nector	No. of Pins	Connector	
CN③a	2	SPEAKER	↔ MAIN CN27
CN③b	3	E.VF (B/W)	↔ MAIN CN12
CN⑤a	12	TOP OPERATION UNIT	↔ MAIN CN18
CN⑥a	13	REAR UNIT	↔ MAIN CN28
CN⑦a	2	MIC	↔ MAIN CN8
CN⑧a	25	MONITOR ASSEMBLY	↔ MAIN CN16
CN⑪a	28	MONITOR CN7601	↔ T. HINGE
CN⑪b	24	MONITOR CN7602	↔ LCD MODULE

<NOTE 2, 3>

- (1) The FPC assembly should be wined around the hinge assembly by two and half turns so that the wire to be connected to the monitor board assembly is positioned inside.
- (2) The upper and lower hinge covers should be mounted so carefully the any wire is not caught into either of the covers.

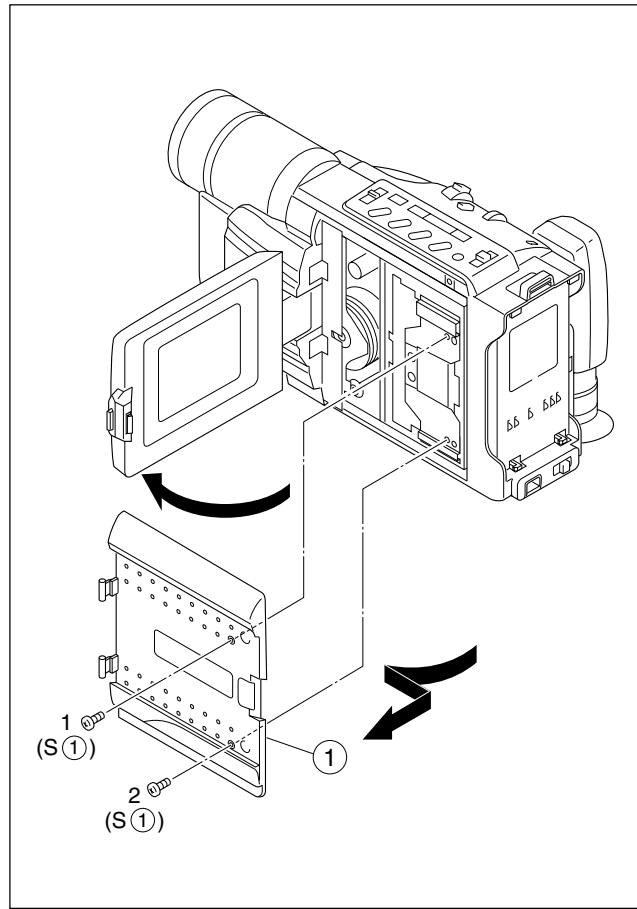

Fig. C1

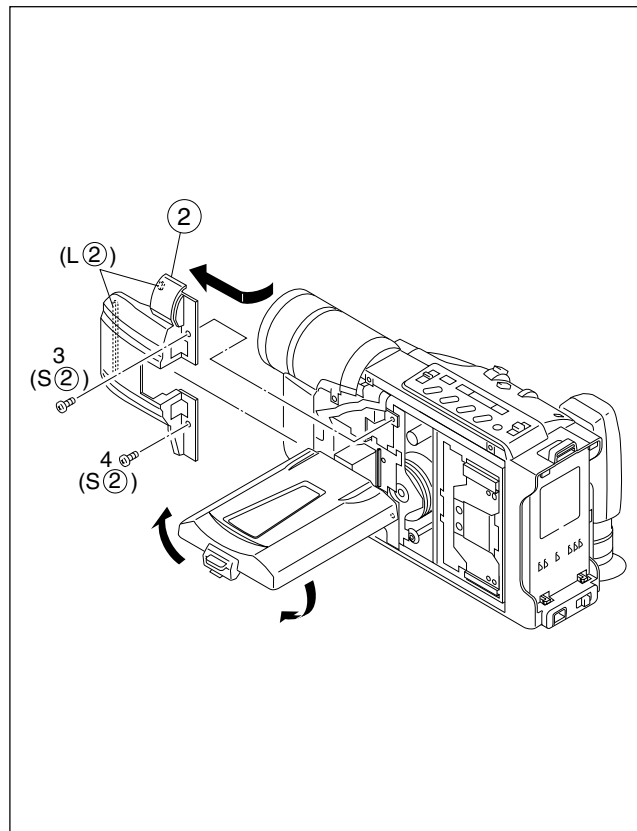

Fig. C2

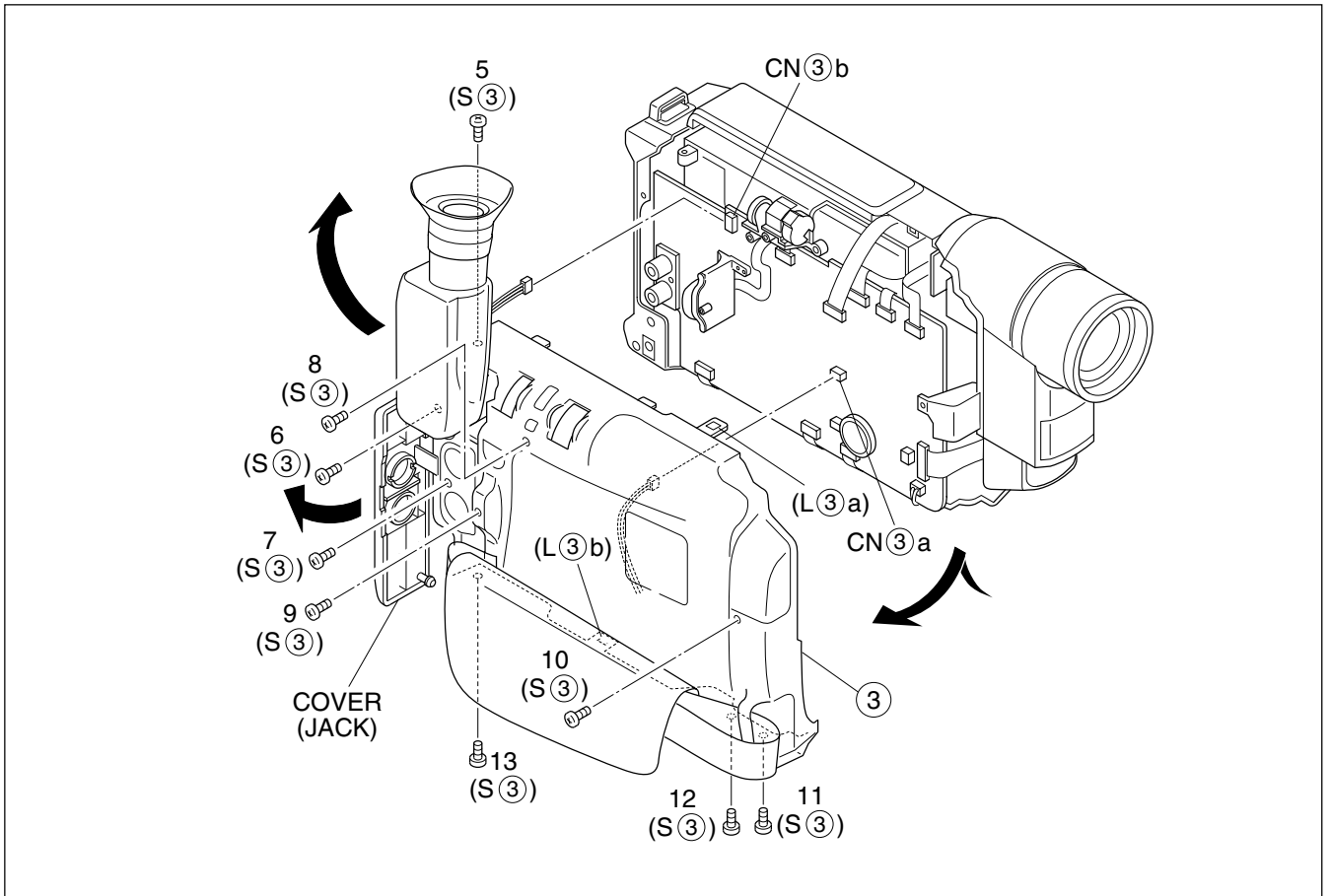

Fig. C3

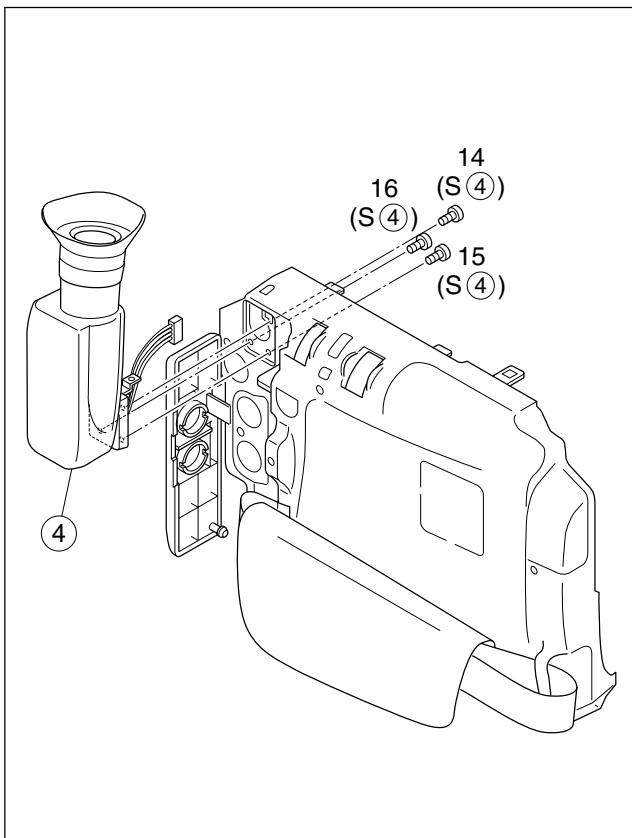

Fig. C4

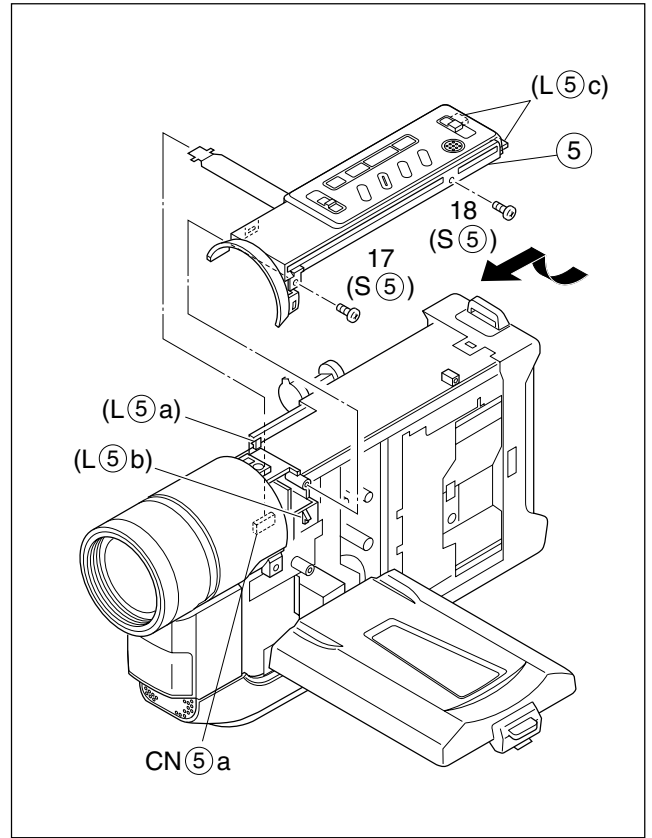

Fig. C5

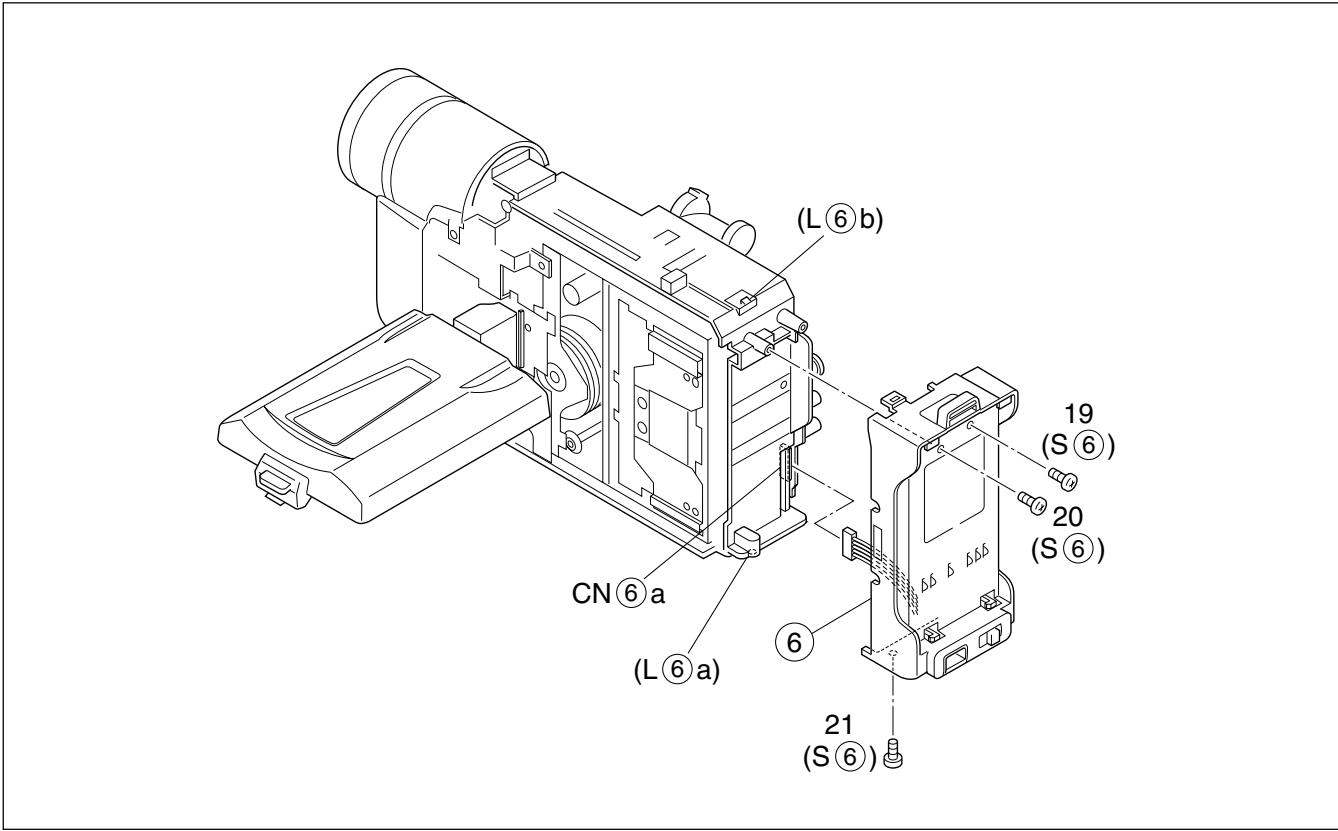

Fig. C6

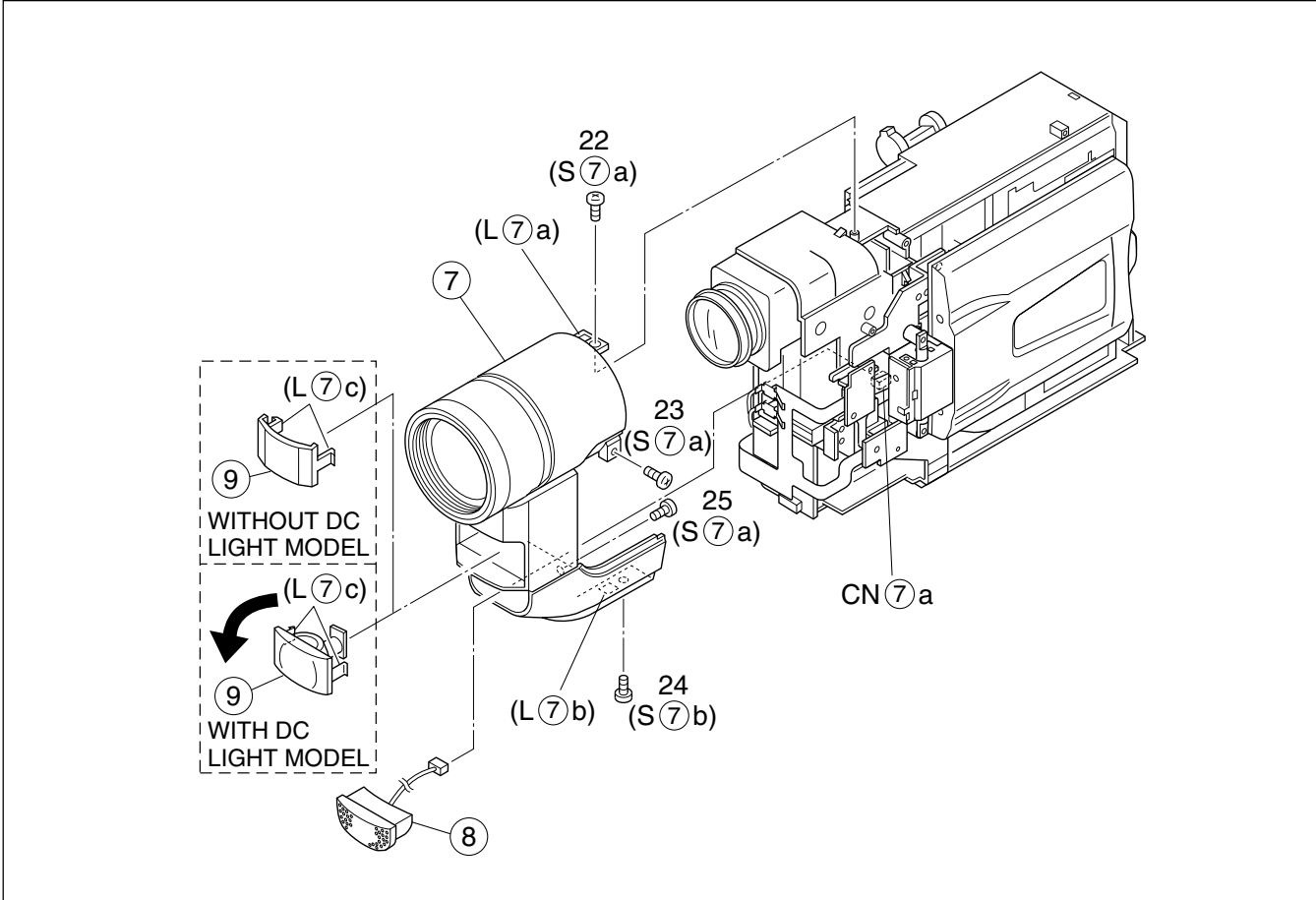

Fig. C7

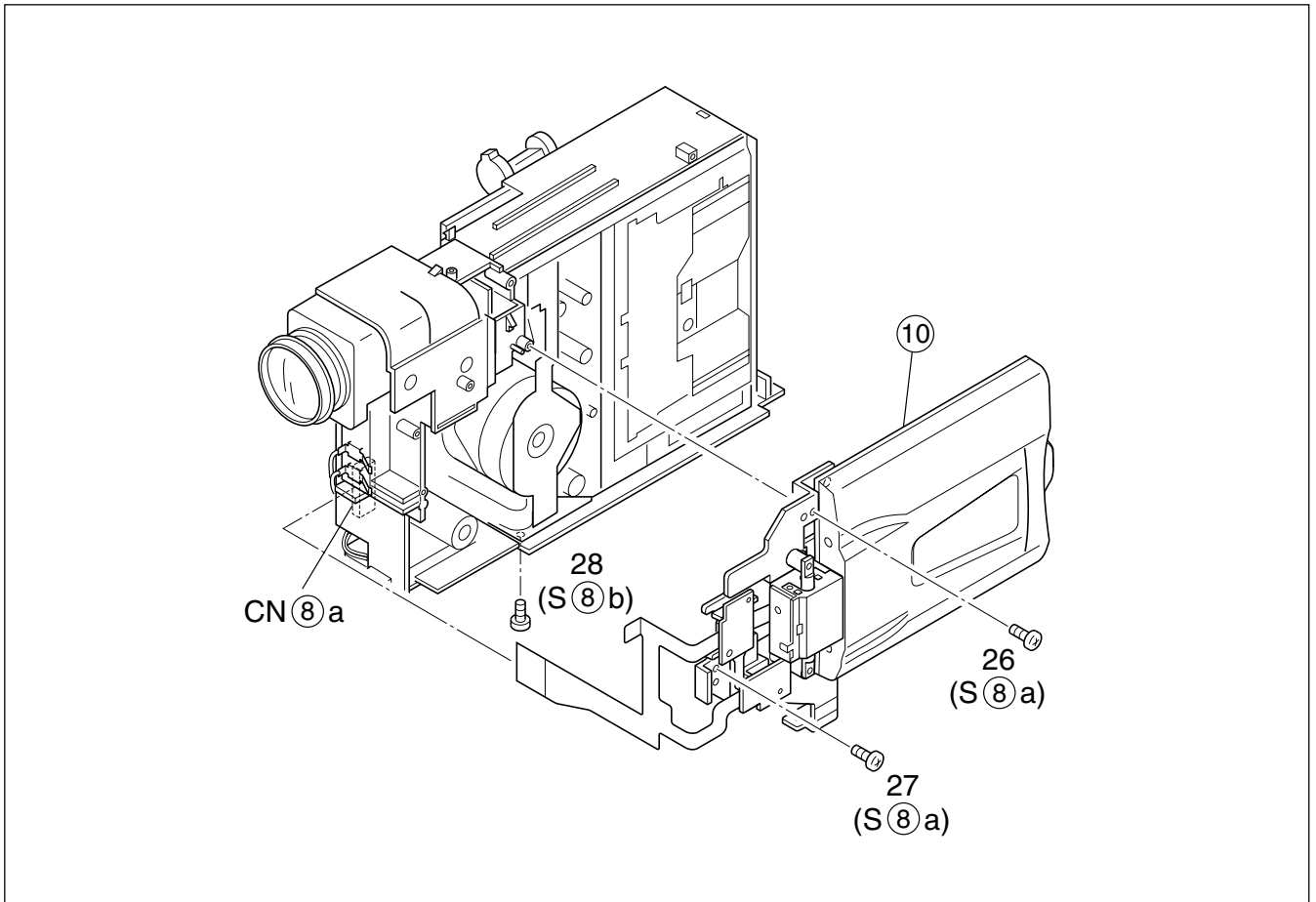

Fig. C8

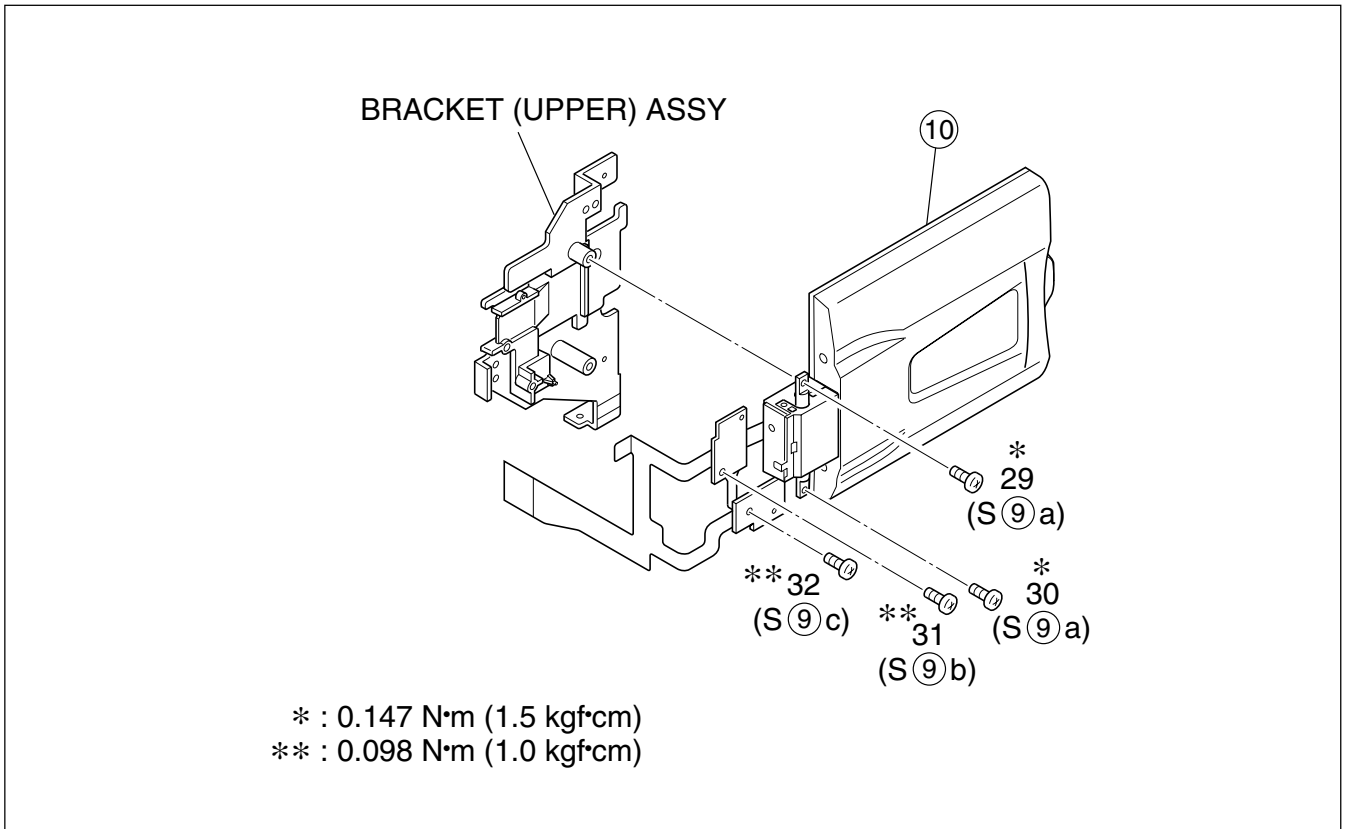

Fig. C9

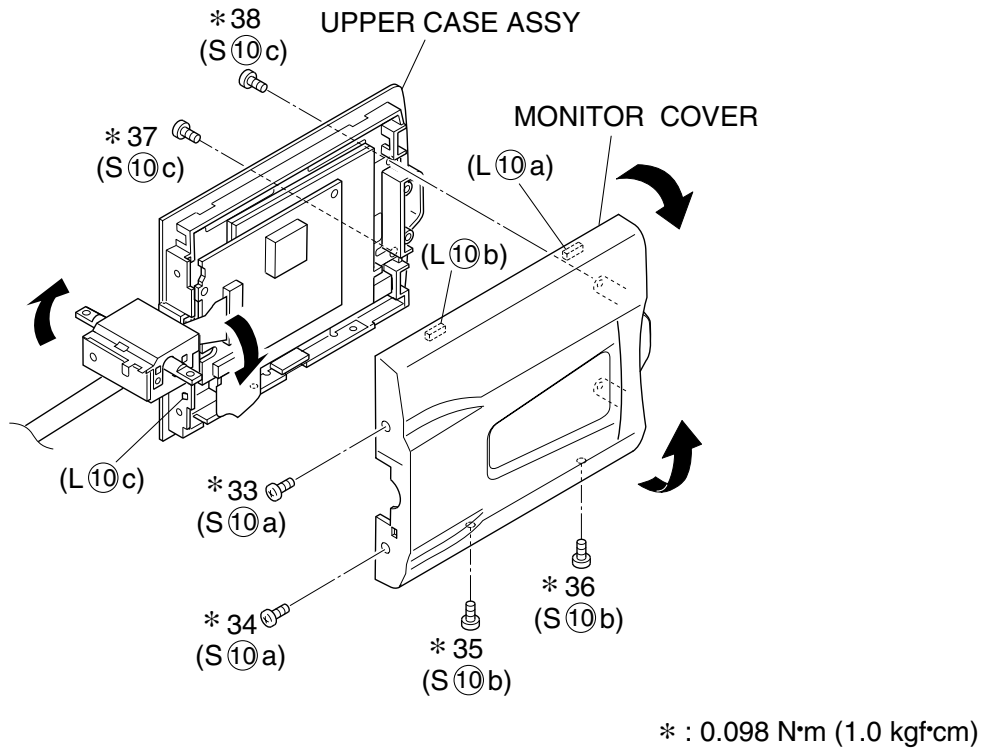

Fig. C10

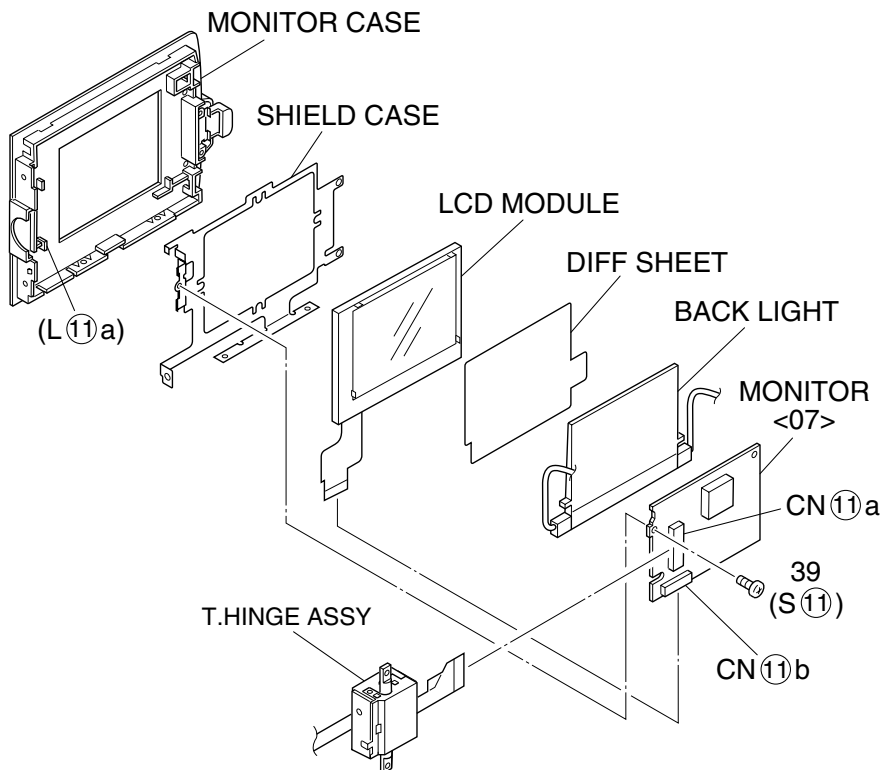

Fig. C11

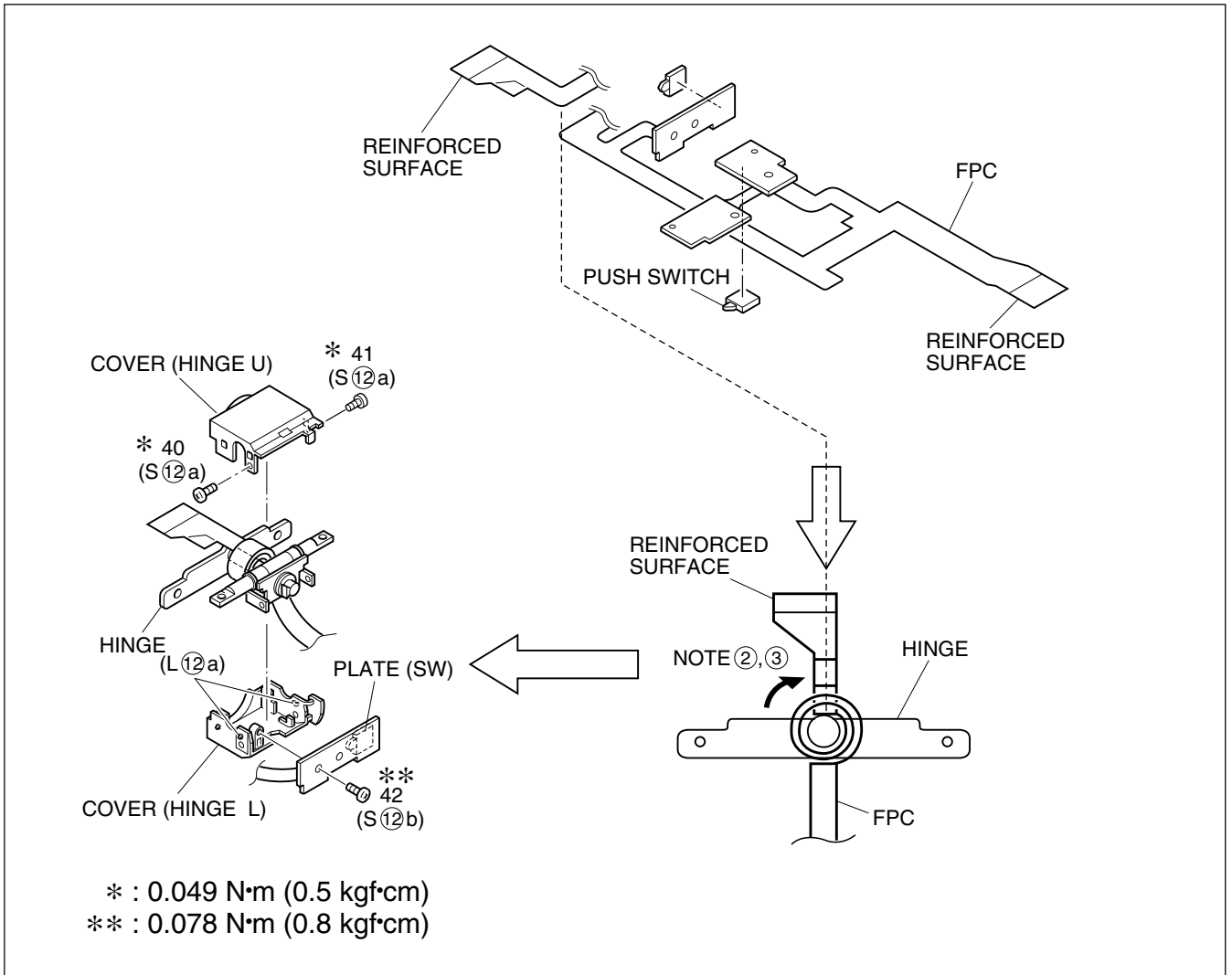

Fig. C12

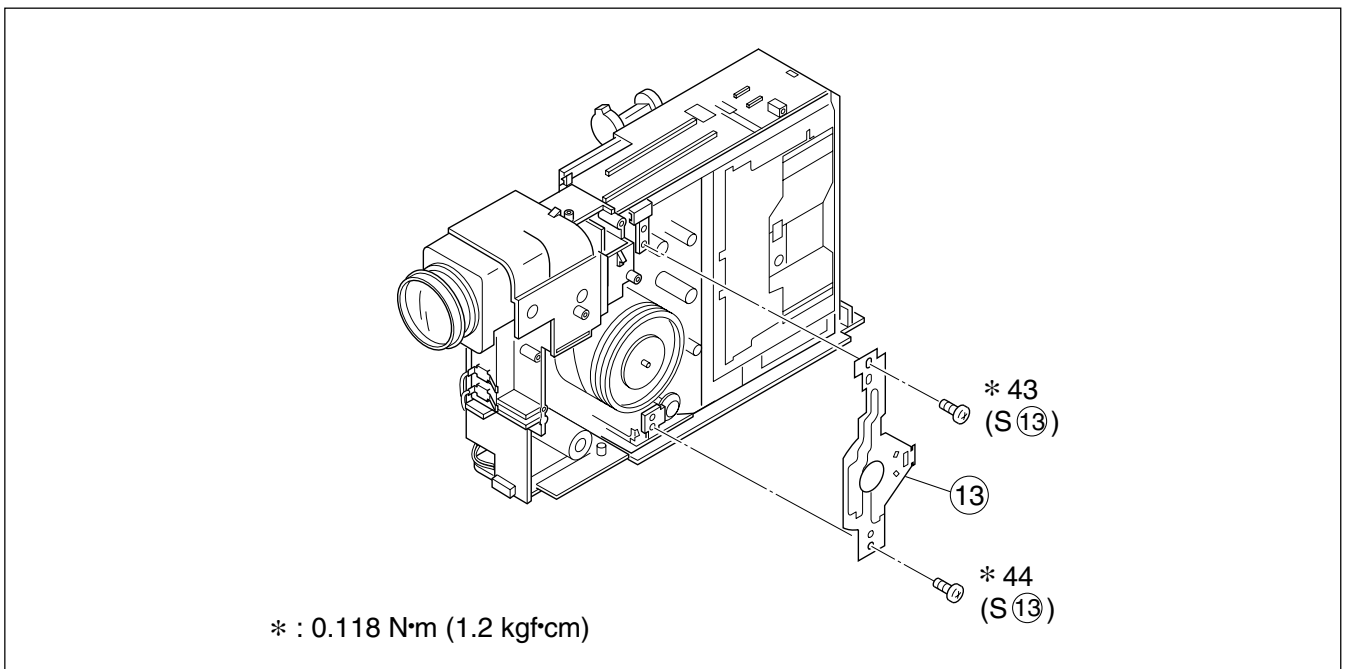

Fig. C13

1.4 DISASSEMBLY/ASSEMBLY OF CAMERA SECTION AND DECK SECTION

1.4.1 Flowchart of disassembly

The following flowchart shows the disassembly of the camera section and deck section. When assembly of the camera section and deck section, follow this flowchart in the reverse order.

<Camera section/Deck section>

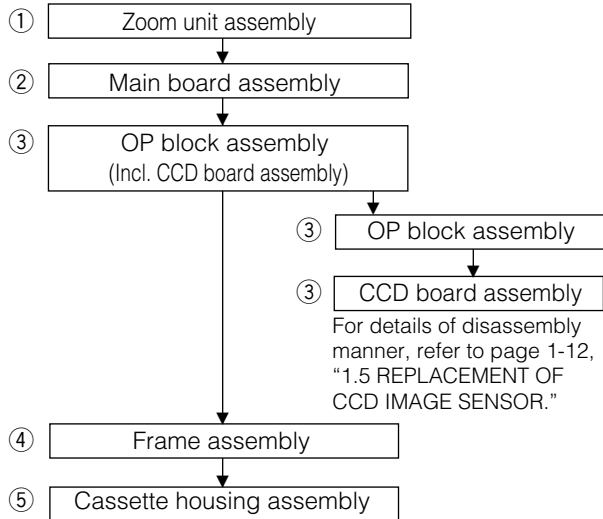

Reference Notes:

<NOTE 1>

Destination of connectors

Note : Two kinds of double-arrows in connection tables respectively show kinds of connector/wires.

⇔ : Flat wire

↔ : Wire

Con- nector	No.of Pins	Connector	
CN①a	14	MAIN CN13	⇔ ZOOM UNIT
CN②a	14	MAIN CN2	⇔ SENSOR
CN②b	11	MAIN CN5	⇔ VIDEO/FLY. E HEAD
CN②c	10	MAIN CN1	⇔ DRUM MOTOR
CN②d	2	MAIN CN4	↔ LOADING MOTOR
CN②e	2	MAIN CN6	↔ DC LIGHT
CN②f	22	MAIN CN15	⇔ OP BLOCK
CN②g	14	MAIN CN22	⇔ CCD
CN②h	11	MAIN CN7	⇔ A/C HEAD
CN②i	18	MAIN CN3	⇔ CAPSTAN MOTOR

1.4.2 Disassembly method

STEP /LOC No.	PART	Fig. No.	REMOVAL
			*UNLOCK/RELEASE/ UNPLUG/UNCLAMP/ UNSOLDER
①	ZOOM UNIT ASSEMBLY	D1	4(S①),(L①a),*CN①a
②	MAIN BOARD	D2	2(S②),(L②a) *CN②a,*CN②b,*CN②c,CN②d, CN②e,*CN②f,*CN②g,*CN②h,*CN②j
③	OP BLOCK ASSEMBLY (Incl. CCD BOARD ASSEMBLY)	D3	2(S③),CUSHON (OP)
④	FRAME ASSEMBLY	D4	2(S④a),2(S④b),(S④c)
⑤	CASSETTE HOUSING ASSEMBLY	D5	4(S⑤)

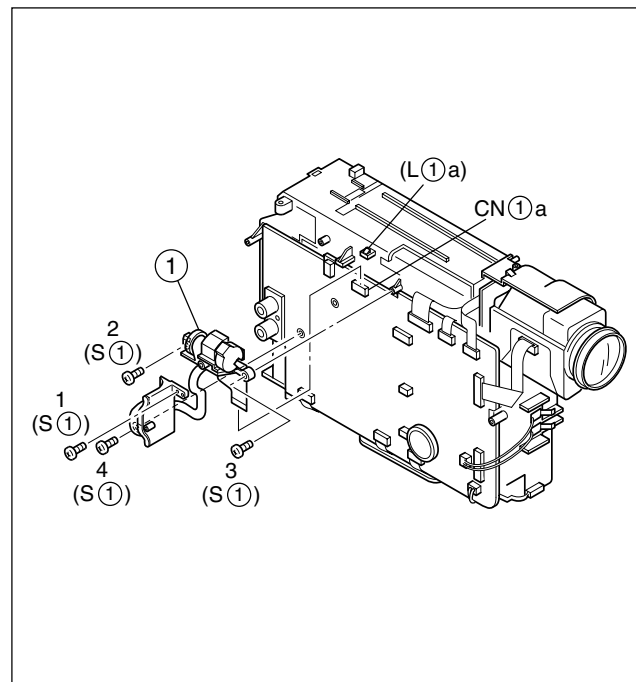

Fig. D1

List of Abbreviations:

2(S①)=2 screws (S①)

4(L①a)=4 Locking Tabs (L①a)

CN=Connector

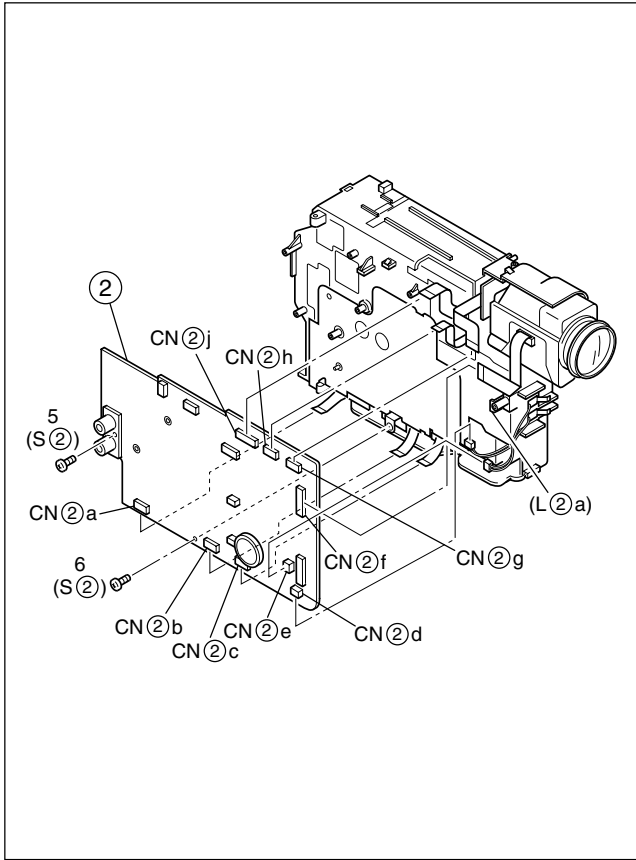
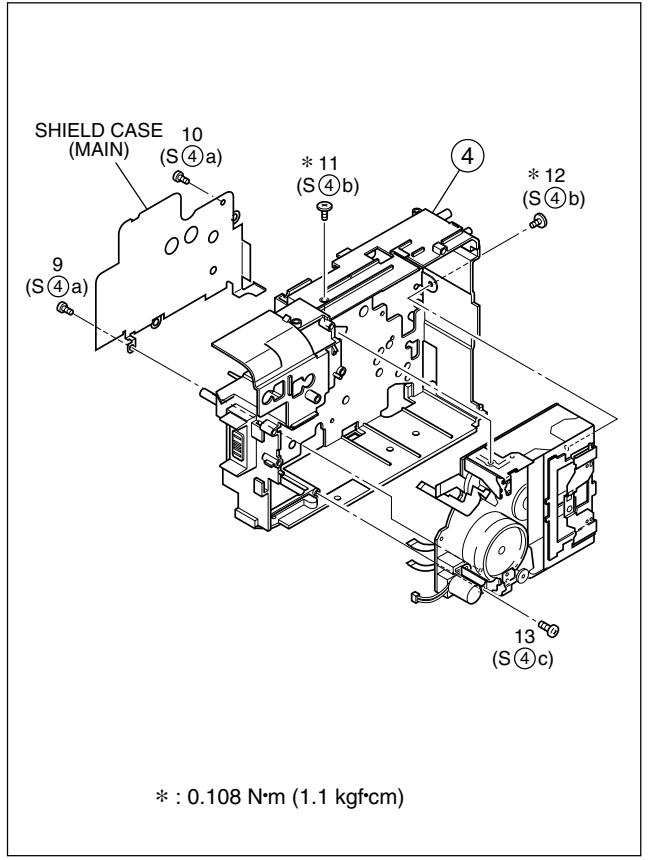

Fig. D2



* : 0.108 N·m (1.1 kgf·cm)

Fig. D4

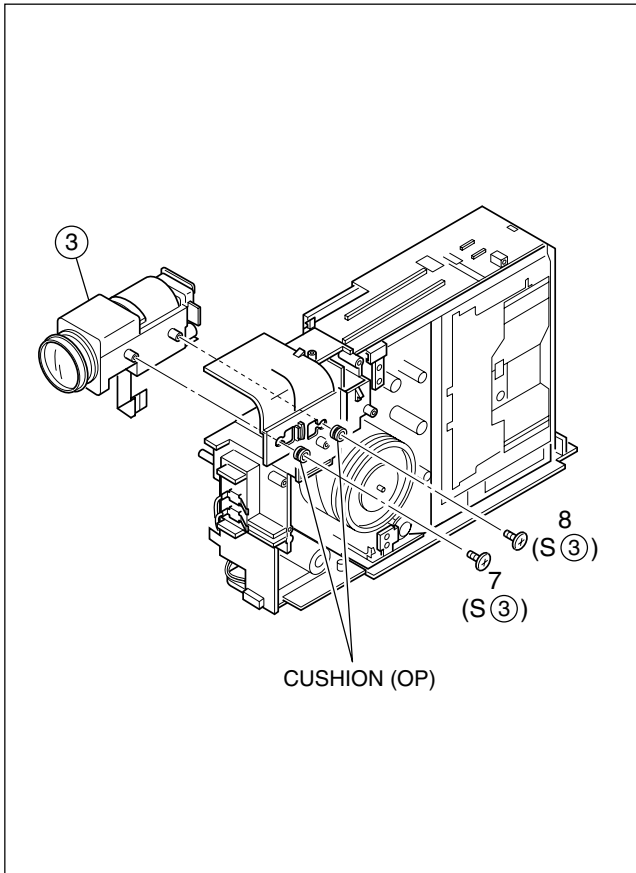
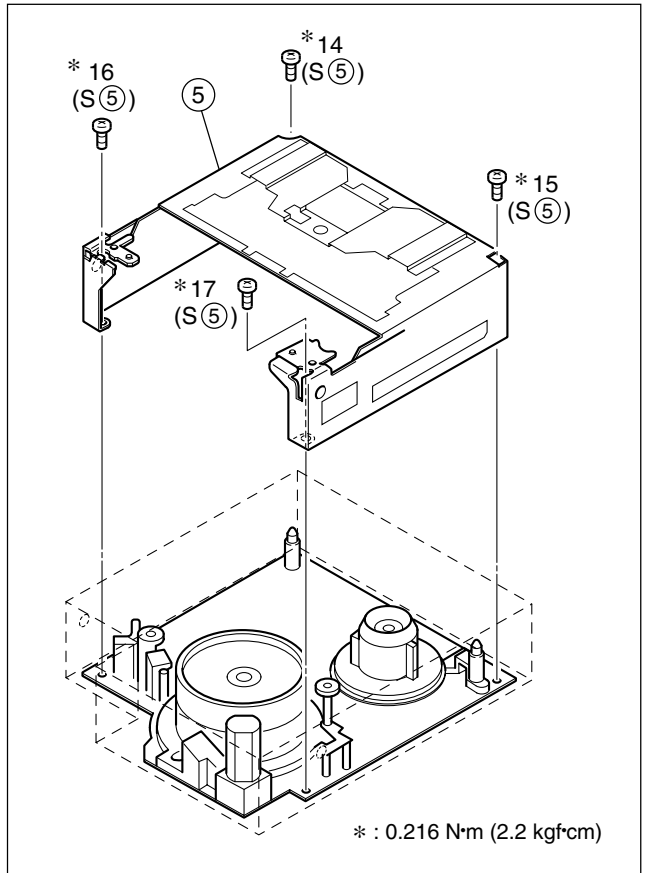

Fig. D3



* : 0.216 N·m (2.2 kgf·cm)

Fig. D5

1.5 REPLACEMENT OF CCD IMAGE SENSOR

Notes:

- Pay the most careful attention to the transparent glass and optical LPF of the CCD image sensor so as not to soil and damage them. If something is soiled with finger-prints, etc., gently clean it with silicon-processed paper/cloth or cham-
ois.
- When the CCD image sensor is shipped from the factory, there are protection seals applied onto the transparent glass. Leave the protector as it is, and take it off just before assembling the CCD image sensor to the OP block.

1.5.1 Removal of CCD image sensor

1. Remove two screws (1, 2) securing the CCD base assy, and disassemble the CCD spacer, the optical LPF, spacer rubber.

1.5.2 Installation of new CCD image sensor

1. Remove the protection seal from a new CCD image sensor. Next, put the optical LPF, spacer rubber, CCD spacer on the CCD image sensor as they are piled up in this order. At that time, make sure of orientation of each item referring to the following table (see Fig. 1-5-1).

Part Name	Orientation
CCD image sensor	Mark is on the right viewed as indicated by the arrow (a).
Spacer rubber	IC side is horizontal.
Optical LPF	Marks are on the left and bottom viewed as indicated by the arrow (a).

2. Fix the CCD base assy to OP block with the two screws (1, 2). At that time, be careful of the orientation.
3. After completion of all P.C. boards to the camera section, observe the monitor to confirm no vignetting caused by the bodytube, rings, lens hood, etc. If no vignetting is observed, it can be said that image's parallel, horizontality and centering are correct.

1.5.3 Replacement of CCD board assy

1. Remove one screw (3).
2. Unsolder at the fourteen points on the CCD board assy.

Note: 1. Remove the screw (3) only when the CCD board assy needs replacement.

2. When installing a new CCD board assy, carry out the above-mentioned procedure in the reverse order.

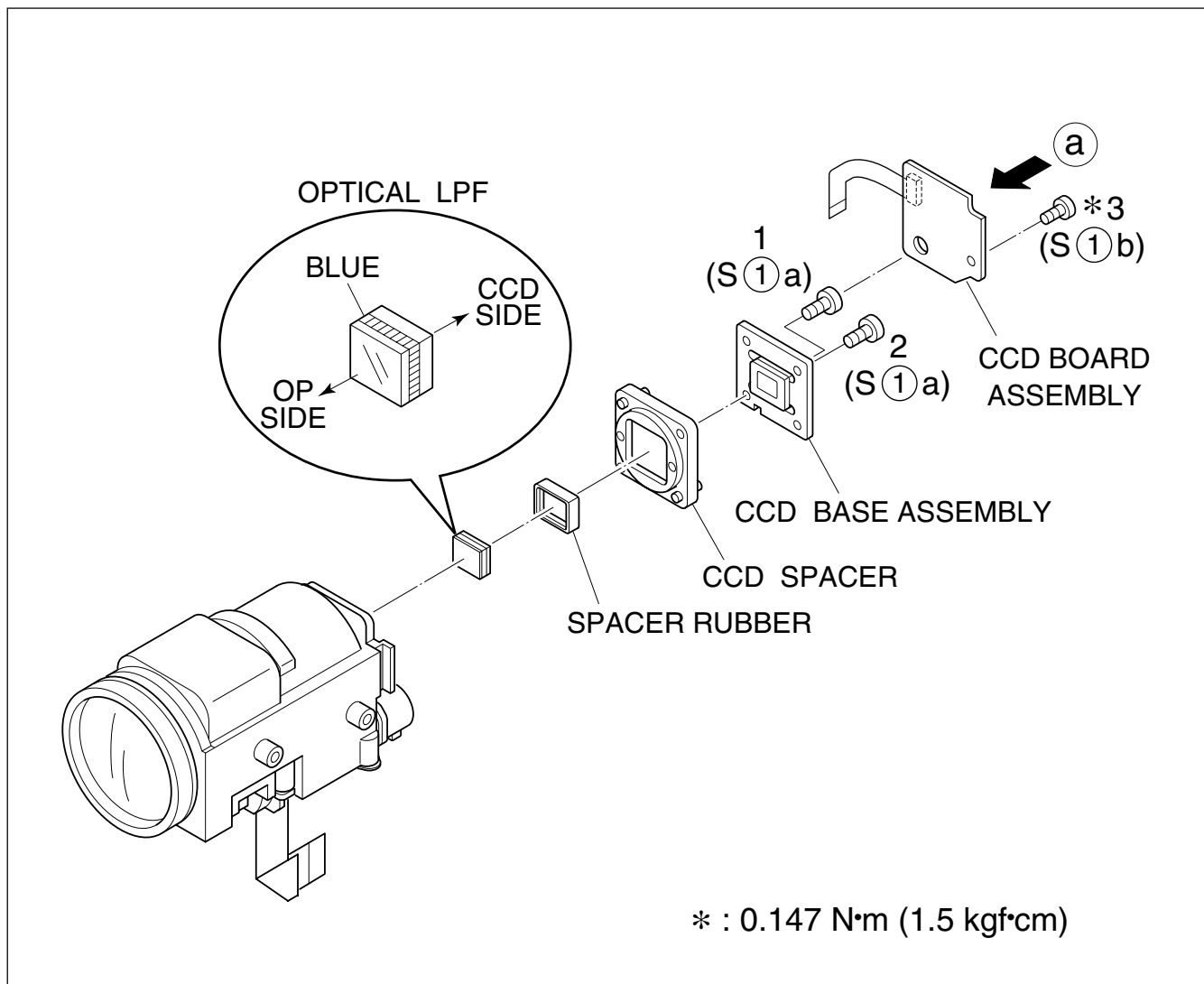

Fig. 1-5-1

1.6 TAKE OUT CASSETTE TAPE

In the event that the set enters the emergency mode as it is loaded with a cassette tape and the cassette tape cannot be ejected with the EJECT button, manually, take it out of the set according to the following procedure.

Note:

- *If the mechanism comes into the unloading mode as the cassette tape is not held by hand, it results in tape damage.*
1. Disconnect the set from the power source.
 2. Remove the cassette cover assembly, Upper case, Lower case assembly, Top operation assembly, Monitor assembly (See Fig. C1, C2, C3, C5 and C8, Pages 1-4 to 1-7).
 3. Connect a jumper wire to each pole of the loading motor as shown by the magnified view (Fig. 1-6-1)

4. While holding down the cassette housing by hand, connect the jumper wires to a battery to run the mechanism to the EJECT position for unloading. If this unloading operation is performed as the cassette housing is not held down by hand, the front lid of the cassette may damage the tape when it is ejected.
5. For taking in the slack of the tape, run the mechanism to the EJECT position as the front lid of the cassette is left open, and turn the take-up gear in the forward direction to wind up the tape. After confirming that the tape has completely been wound up and the supply reel is idling, take the cassette tape out of the cassette housing.

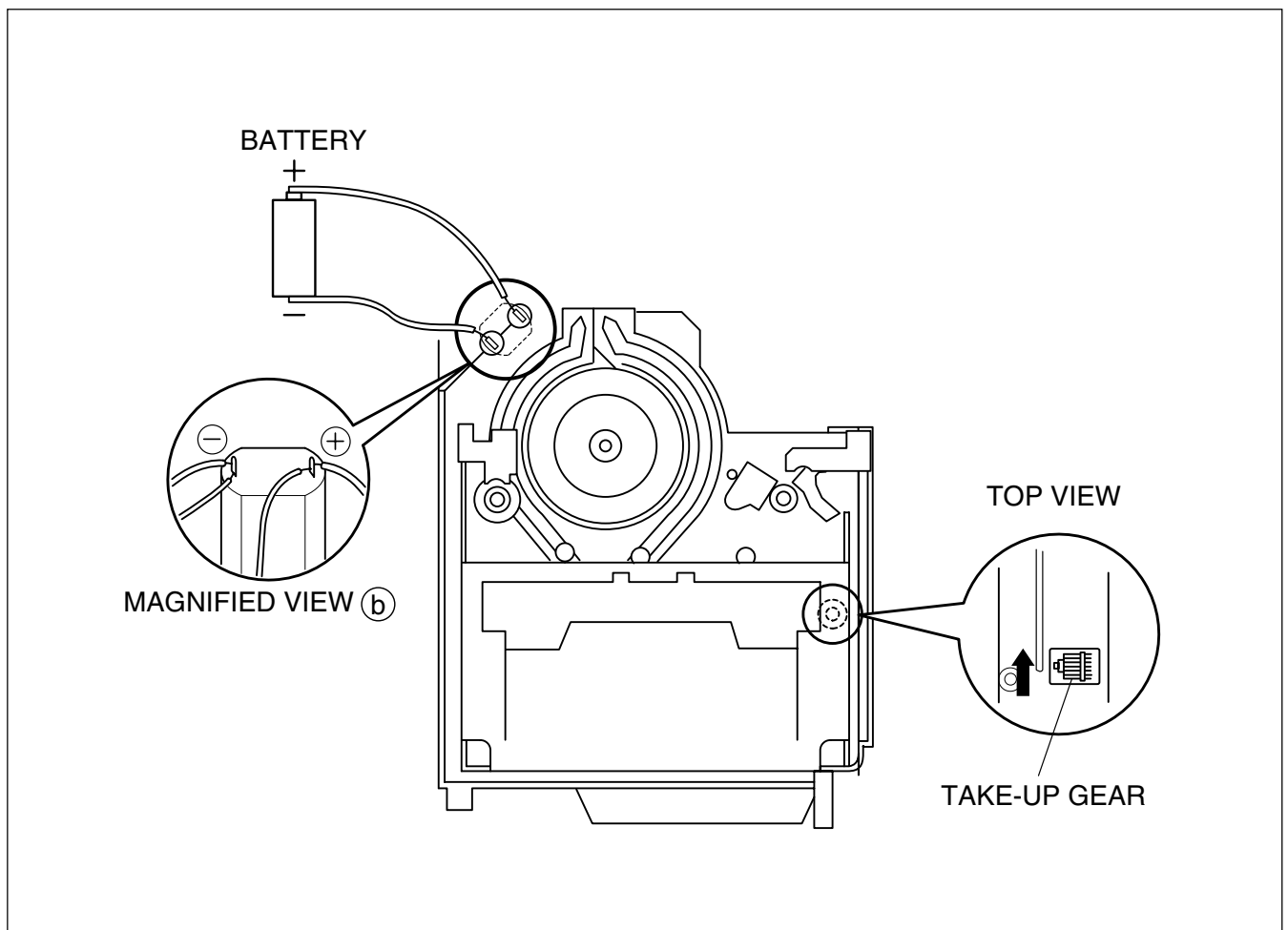

Fig. 1-6-1

1.7 EMERGENCY DISPLAY

Whenever some abnormal signal is input to the mechacon CPU, an error number (E01, as an example) is displayed in the electronic view finder.

In every error status, such the message as shown below alternately appear over and over.

- In an emergency mode, all operations except turning on/off the POWER switch are ineffectual.

Example (in case of the error number E01):

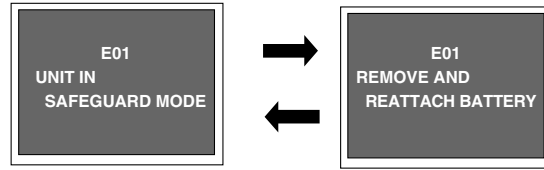

E. VF	Symptom	Mode when observed	Resulting mode
E07	Short circuit of capstan MDA	Power ON	Power OFF
E06	CAPSTAN FG input absent	EDIT	Power OFF
E04	DRUM FF input absent	DRUM rotation	Power OFF
E03	SUPPLY REEL FG input absent	REC, PLAY, SEARCH, FF	UNLOADING → Power OFF
E02	Mode control motor rotates for more than 10 sec without shift to next mode	UNLOADING	Power OFF
E01	Mode control motor rotates for more than 10 sec without shift to next mode.	LOADING	Power OFF
E00	Overtime the programming transaction	REC, PLAY	Power OFF

1.8 DEMONSTRATION MODE

This model has the DEMONSTRATION mode.

- 1) How to set the DEMONSTRATION mode.
The camera can be entered into the DEMONSTRATION mode by setting on the DISPLAY screen appearing in the viewfinder.

When entering the camera into the DEMONSTRATION mode, pay heed to the following matters.

No cassette is set in the camcorder or a cassette is set in the camcorder but it is protected from recording.

Note: 1) The indications of the DISPLAY page very depending on the setting.

- 2) How to cancel the DEMONSTRATION mode.
To cancel the DEMONSTRATION mode, turn the POWER switch off ("POWER OFF").

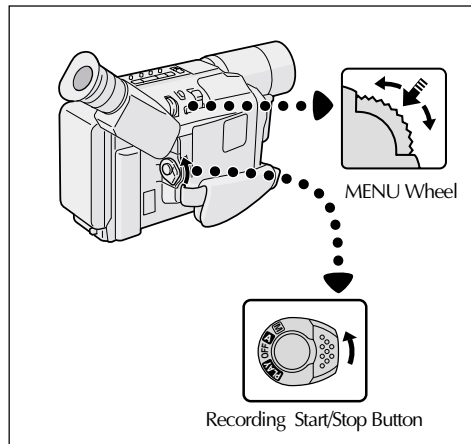
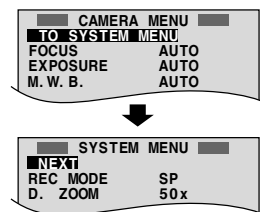

Fig. 1-8-1

1. Set the POWER switch to turn on the "M".
Press the MENU WHEEL once.
The first page of the DISPLAY appears on the LCD monitor (or in the viewfinder).



Display 1

2. Turn the MENU WHEEL in the direction of the arrow to set the cursor at "NEXT".
Press the MENU WHEEL once.
The second page of the DISPLAY appears on the LCD monitor (or in the viewfinder).

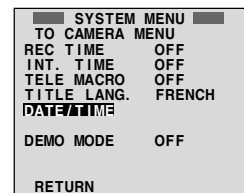

Display 2

See to next page

Note: 2) As the "DEMO MODE" is executed, the camcorder enters the DEMONSTRATION mode after the title screen of "TITLE CALL" and "FUTURE" appear in this order.

<Flow chart>

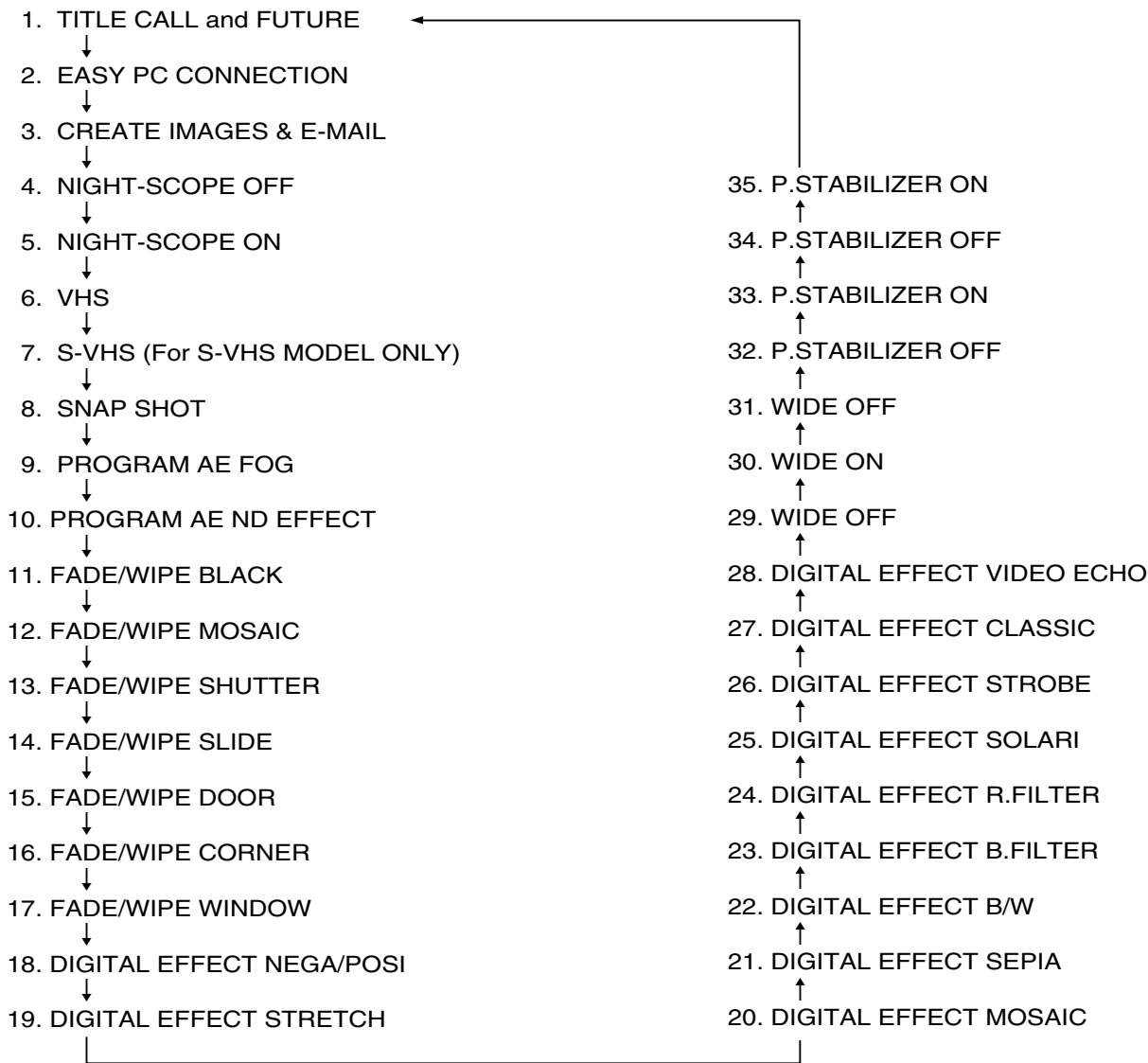
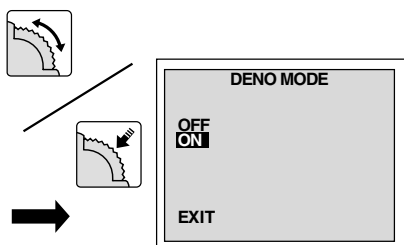

Fig. 1-8-2

3. Turn the MENU WHEEL in the direction of the arrow to set the cursor at "DEMO MODE". Then, press the MENU WHEEL once. The third page of the DEMO MODE appears on the LCD monitor (or in the viewfinder).

4. Turn the MENU WHEEL in the direction of the arrow to set the cursor at "ON". Then, press the MENU WHEEL once. The fourth page of the DISPLAY appears on the LCD monitor (or in the viewfinder). ("DEMO MODE" is switched "ON" from "OFF" status.)

5. Press the MENU WHEEL once. The camcorder automatically enters the DEMONSTRATION mode and it repeats demonstration operation. While the camcorder is performing demonstration, all operations except turning on/off the POWER switch are ineffectual.



Display 3

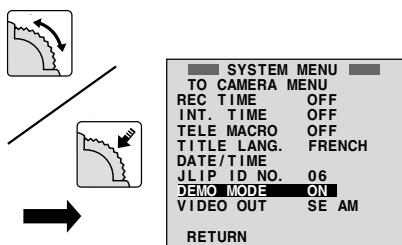

Display 4

Refer to Fig. 1-8-2. While the DEMONSTRATION mode is activated, a word of DEMONSTRATION is appearing on the screen scrolling from right to left.

1.9 SERVICE NOTE

MAIN ASS'Y

Symbol No.	①	②	③										④	⑤	⑥	⑦ (⑧, ⑨)													
Removing order of screw	1	2	3	4	5	6	7	8	9	10	11	12	13	14	15	16	17	18	19	20	21	22	23	24	25				
Place to stick screw																													
Reference drawing	Fig. C1	Fig. C2	Fig. C3																							Fig. C4	Fig. C5	Fig. C6	Fig. C7
Screw tightening torque	I																												

Symbol No.	⑩																										⑪
Removing order of screw	26	27	28	29	30	31	32	33	34	35	36	37	38	39	40	41	42	43	44								
Place to stick screw				*	*	*		*	*	*																	
Reference drawing	Fig. C8			Fig. C9						Fig. C10				Fig. C11					Fig. C12							Fig. C13	
Screw tightening torque	I			V		II				II				I					VI		VII					III	

DECK ASS'Y

Symbol No.	①	②						③	④						⑤		
Removing order of screw	1	2	3	4	5	6	7	8	9	10	11	12	13	14	15	16	17
Place to stick screw																	
Reference drawing	Fig. D1	Fig. D2	Fig. D3	Fig. D4										Fig. D5			
Screw tightening torque	I						I		IV				I				VIII

OP B LOCK ASS'Y

Symbol No.	③		
Removing order of screw	1	2	3
Place to stick screw			
Reference drawing	Fig. 1-5-1		
Screw tightening torque	I		V

< NOTE >

- 1) *: Don't reuse the screw, because screw lock bond was applied to them.
- 2) Pay careful attention to tightening torque for each screw.

- | | | |
|----------------------------|-----------------------------|----------------------------|
| I : 0.196N·m (2.0kgf·cm) | II : 0.098N·m (1.0kgf·cm) | III : 0.118N·m (1.2kgf·cm) |
| IV : 0.108N·m (1.1kgf·cm) | V : 0.147N·m (1.5kgf·cm) | VI : 0.049N·m (0.5kgf·cm) |
| VII : 0.078N·m (0.8kgf·cm) | VIII : 0.216N·m (2.2kgf·cm) | |

Table 1-9-1

SECTION 2 MECHANISM ADJUSTMENT

2.1 SERVICE CAUTIONS

2.1.1 Precautions

1. Before disassembling/re-assembling the set as well as soldering parts, make sure to disconnect the power cable.
2. When disconnecting/connecting connectors, pay enough attention to wiring not to damage it.
3. When installing parts, be careful not to do with other parts as well as not to damage others. (Pay the most careful attention to the upper drum assy and tape transport mechanism.)

2.1.2 How to read the disassembly and assembly (For Mechanism Parts)

- (1) Order of steps in Procedure
When reassembling, perform the step(s) in the reverse order. These numbers are also used as the identification (location) No. of parts Figures.
- (2) Part to be removed or installed.
- (3) Location of part.
T = Top
B = Bottom
- (4) Fig. No. showing Procedure or Part Location.
M = Mechanism
- (5) Identification of part to be removed, unhooked, unlocked, released, unplugged, unclamped or unsoldered.
P = Spring
W = Washer
S = Screw
* = Unhook, unlock, release, unplug or unsolder.
- (6) Adjustment information for installation.
(+) = Refer to Exploded Views for Lubrication information.

(For Mechanism Parts)

STEP/LOC. No.	PART	Fig. No.	REMOVAL		INSTALLATION	
			*UNHOOK/UNLOCK /RELEASE/UNPLUG /UNSOLDER		ADJUSTMENT CONDITION	NOTE
①	ROLLER BASE ASSEMBLY	T	M1	(S1)		-
②	TENSION ARM ASSEMBLY	T	M1	(P1), (W1a)		-
③	REEL DISC (SUP)	T	M1	(W1a), (W1b)		-

↑
(1)

↑
(2)

↑
(3)

↑
(4)

↑
(5)

↑
(6)

2.1.3 Required adjustment tools



1	Alignment tape MHPE-C	2	Alignment tape MHPE-LC
			
3	Jig connector cable YTU93106A	4	Extension connector YTU94145B-30
			
5	Cassette torque meter PUJ50431-2	6	Roller Driver PTU94002-2
			

Table 2-1-1

1,2. Alignment tape

To be used for check and adjustment of interchangeability of the mechanism.

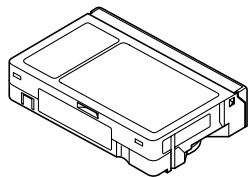
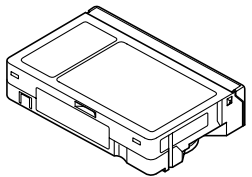
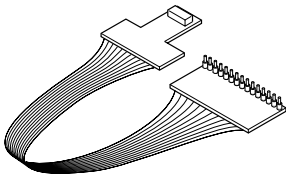
(Video: Color bar signal, Audio: Non-signal)

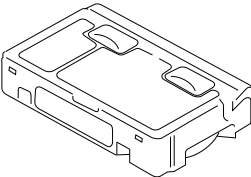
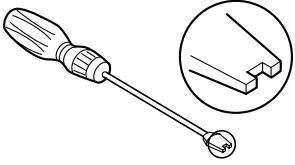
3. JIG connector cable

Connected to CN25 of the main board and used for measuring error rates, etc.

4. Extension connector

To be used to JIG connector cable

5. Cassette Torque Meter

This is used to check the back tension and play torque during mechanism adjustment.

6. Roller Driver

To be used to turn the roller driver to adjustment of the linearity of playback envelope.

2.2 DISASSEMBLY/ASSEMBLY OF MECHANISM PARTS

This procedure starts with the condition that the cabinet parts and deck parts. Also, all the following procedures for adjustment and parts replacement should be performed in STOP mode. When reassembling, perform the step(s) in the reverse order.

STEP/LOC. No.	PART	T	Fig. No.	REMOVAL	INSTALLATION
				*UNHOOK/UNLOCK /RELEASE/UNPLUG /UNSOLDER	ADJUSTMENT CONDITION NOTE
①	ROLLER BASE ASSEMBLY	T	M1	(S1)	-
②	TENSION ARM ASSEMBLY	T	M1	(P1), (W1a)	-
③	REEL DISC (SUP)	T	M1	(W1a), (W1b)	-
④	SLANT ARM ASSEMBLY	T	M1	(W1a)	-
⑤	CANCEL LEVER ASSEMBLY	T	M2	(W2)	-
⑥	EJECT LEVER ASSEMBLY	T	M2	(W2)	-
⑦	CASSETTE GUIDE (L) ASSEMBLY	T	M2	(S2)	-
⑧	SUPPLY CLUTCH ASSEMBLY	T	M2	(W2)	-
⑨	WHEEL GEAR	T	M2	(W2)	See, Adjustment procedure for Section 2.3
⑩	ROTARY ENCODER	B	M3	4(S3a)	The function of this part varies according to the assembly (VHS/S-VHS) which this part is incorporated in.
⑪	TIMING BELT	B	M3	-	-
⑫	CENTER PULLEY UNIT	T/B	M3	2(S3a)	-
⑬	CASSETTE GUIDE (R) ASSEMBLY	T	M3	(S3b), (P3)	(Only use S-VHS model)
⑭	TU GEAR	T	M3	(W3a)	-
⑮	BRAKE SUB GEAR	T	M3	(W3a)	-
⑯	P.R ARM ASSEMBLY	T	M3	(W3b)	-
⑰	TU GUIDE ARM ASSEMBLY	T	M3	(W3a)	-
⑱	LINK ARM ASSEMBLY	T	M4	(W4)	-
⑲	LED GUIDE	T	M4	(S4a)	-
⑳	A/C HEAD UNIT	T	M4	2(S4b)	-
㉑	SLANT POLE BASE ASSEMBLY	T	M5	(S5a)	-
㉒	CAP MOTOR ASSEMBLY	T	M5	3(S5a)	-
㉓	MOTOR BASE	T	M5	2(S5b), (S5c)	-
㉔	BRUSH	B	M6	(S6a)	-
㉕	DRUM FINAL	T/B	M6	2(S6b), 2(S6c) *CATCHER	-
㉖	GUIDE RAIL	T	M6	8(S6d)	-
㉗	POLE BASE (SUP)	T	M6	-	-
㉘	POLE BASE (TU)	T	M6	-	-
㉙	COVER PLATE	T	M7	-	-
㉚	DRIVE LEVER ASSEMBLY	T	M7	-	-
㉛	MOTOR BRACKET ASSEMBLY	T	M7	3(S7)	-
㉜	CONTROL CAM	T	M8	(W8a)	See, Adjustment procedure for Section 2.3
㉝	LINK LEVER	T	M8	-	-
㉞	MIDDLE GEAR	T	M8	-	-
㉟	LOADING GEAR(T) ASSEMBLY	T	M8	(W8b)	See, Adjustment procedure for Section 2.3
㊱	LOADING GEAR(S) ASSEMBLY	T	M8	(W8b)	-
㊲	LOADING RING ASSEMBLY	T	M8	4(S8)	See, Adjustment procedure for Section 2.3

Table 2-2-1

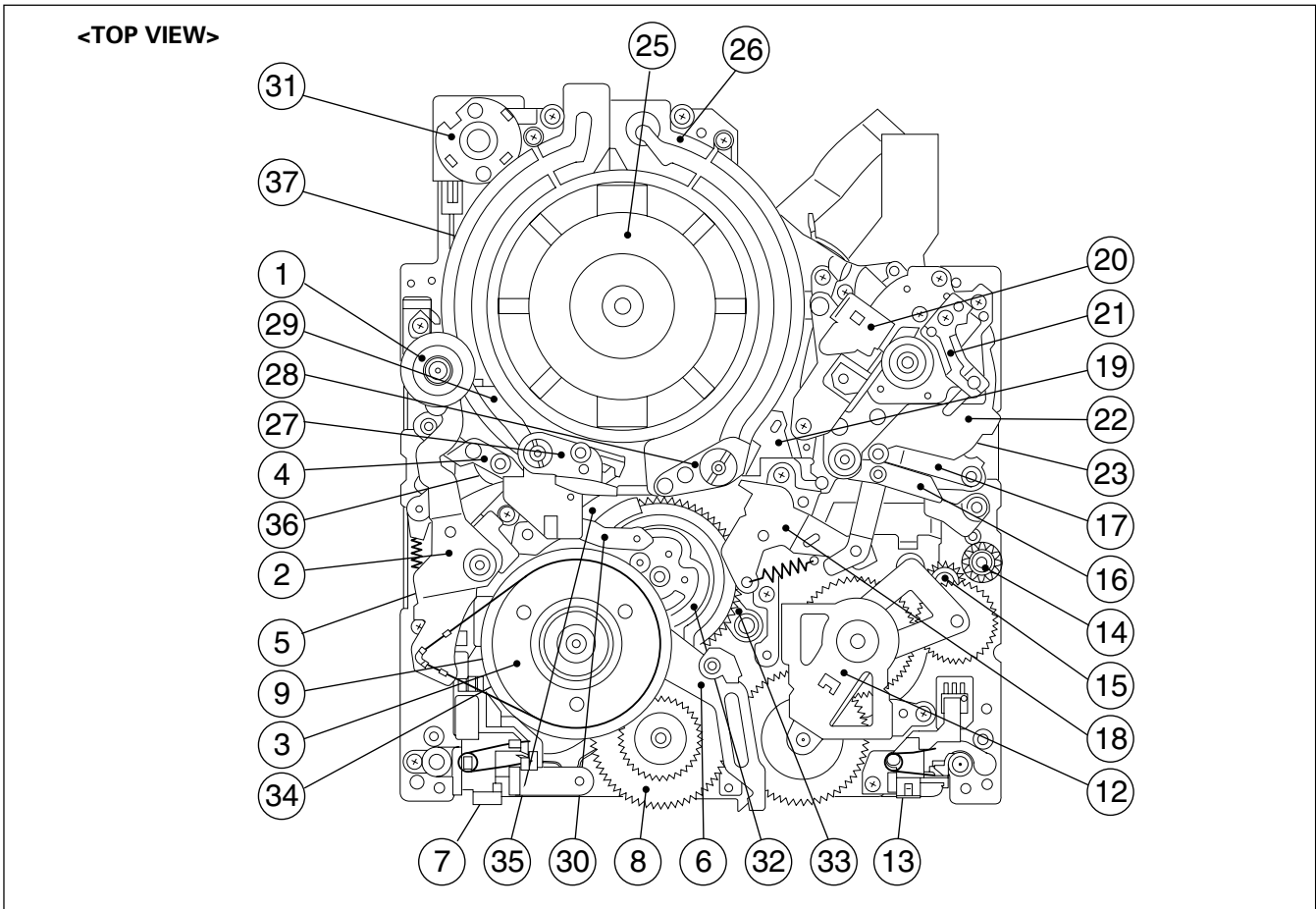

Fig. 2-2-1 TOP VIEW

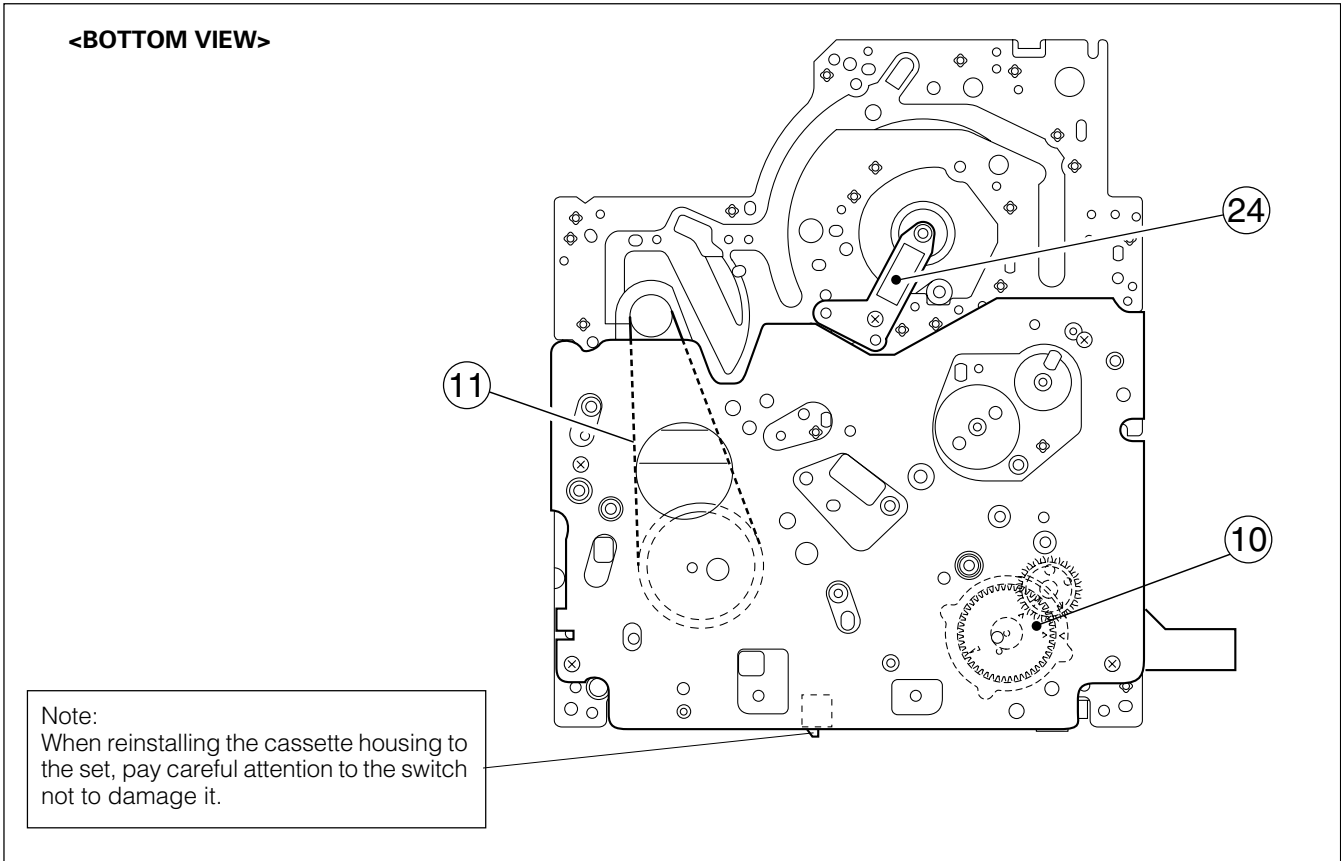

Fig. 2-2-2 BOTTOM VIEW

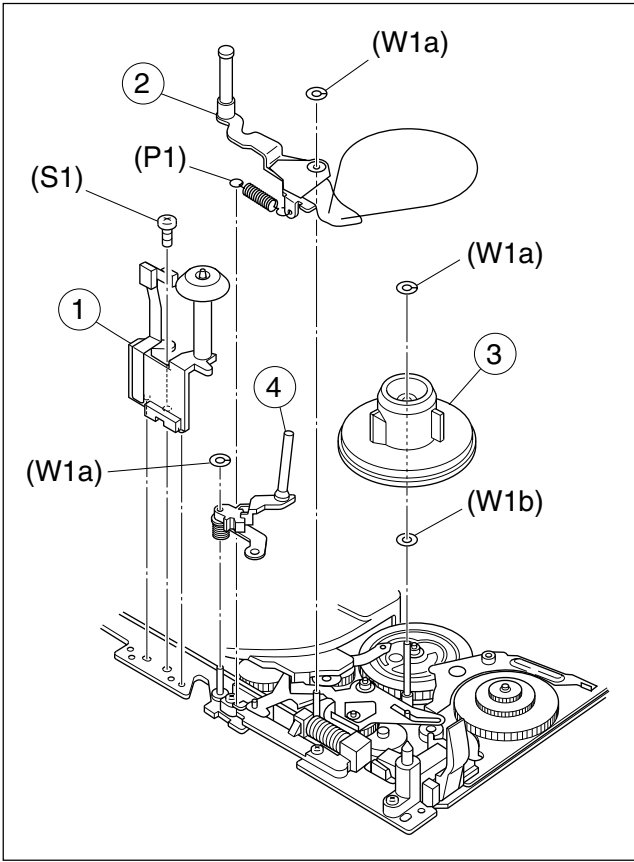

Fig. M1

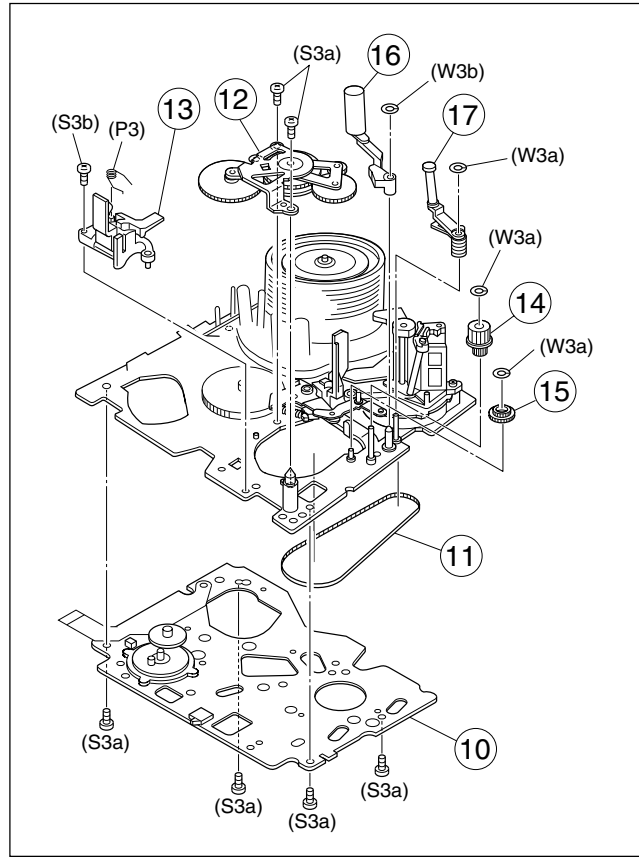

Fig. M3

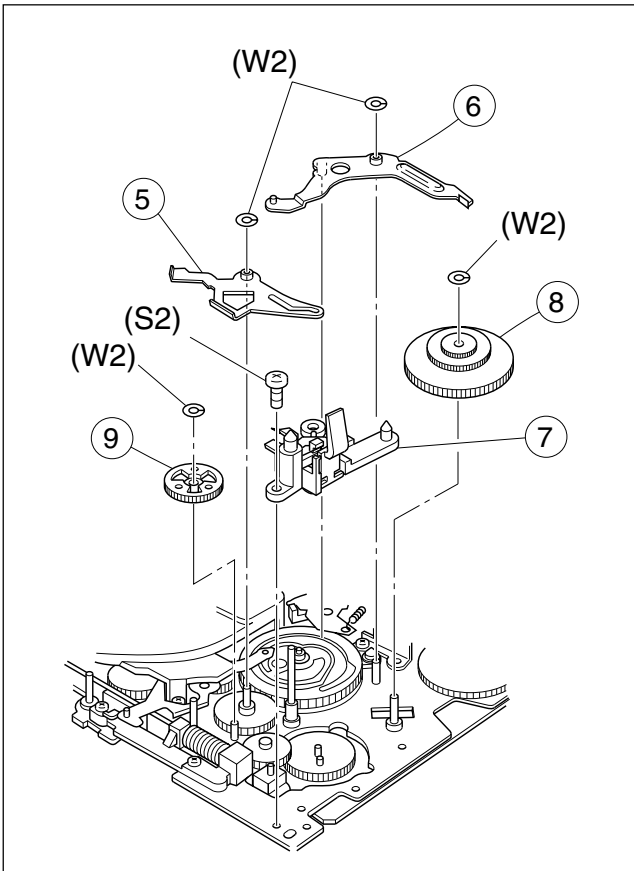

Fig. M2

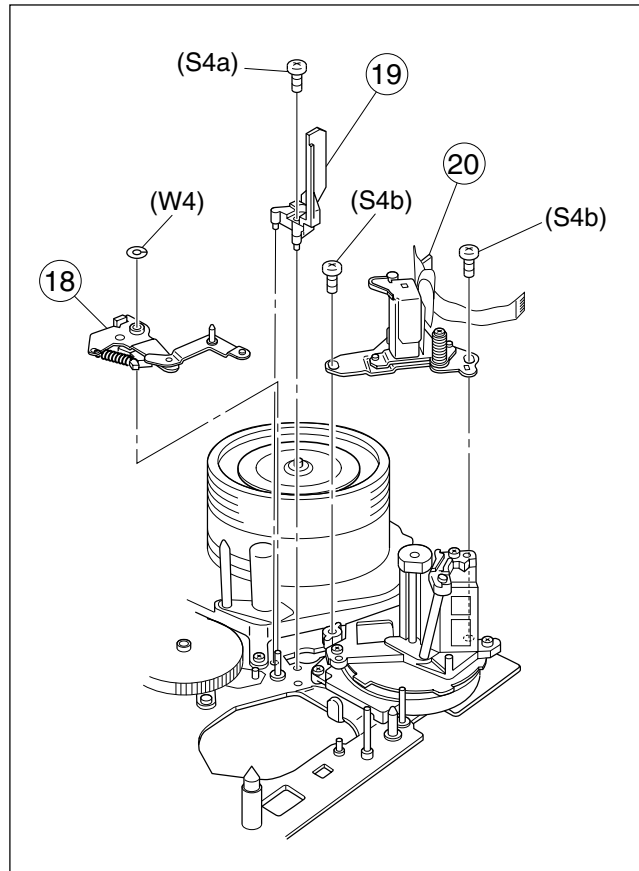

Fig. M4

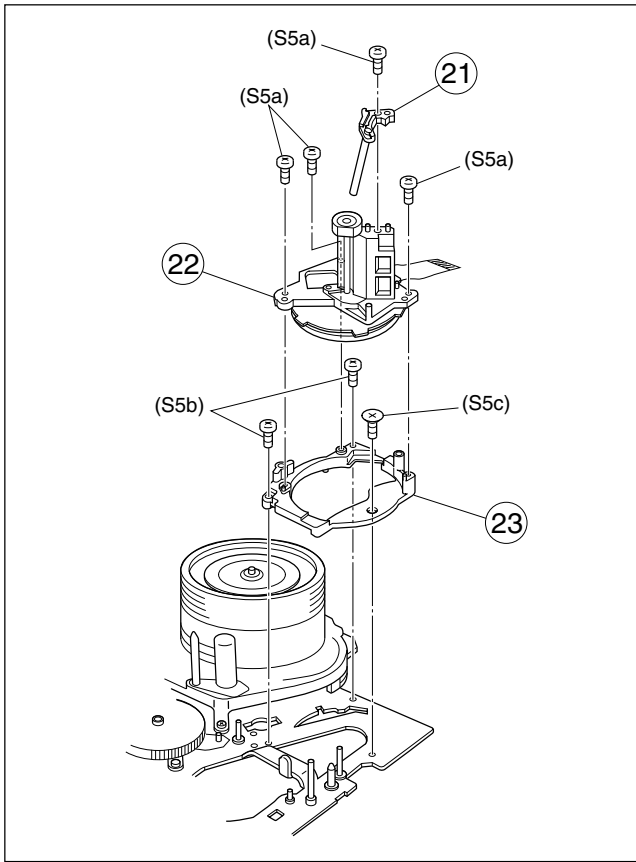

Fig. M5

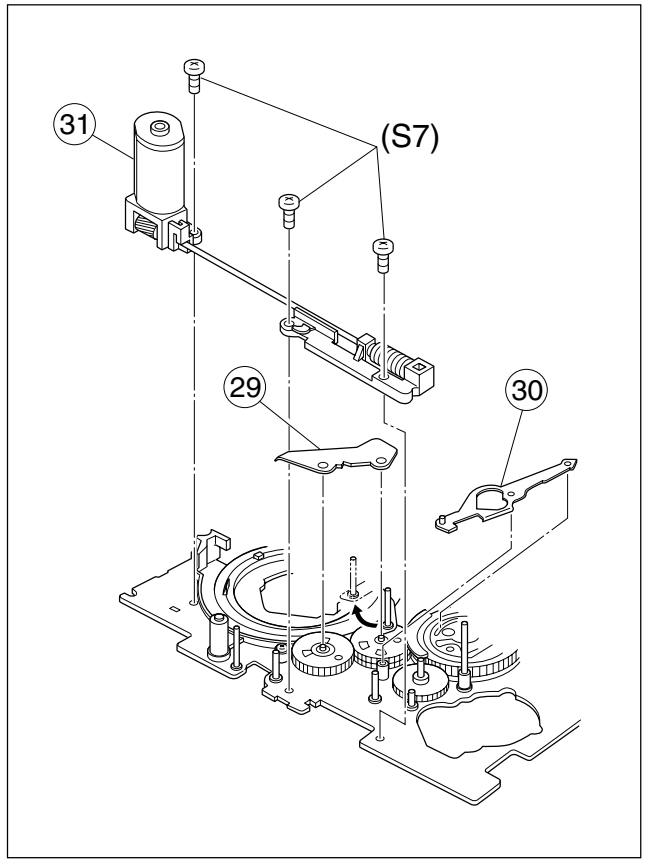

Fig. M7

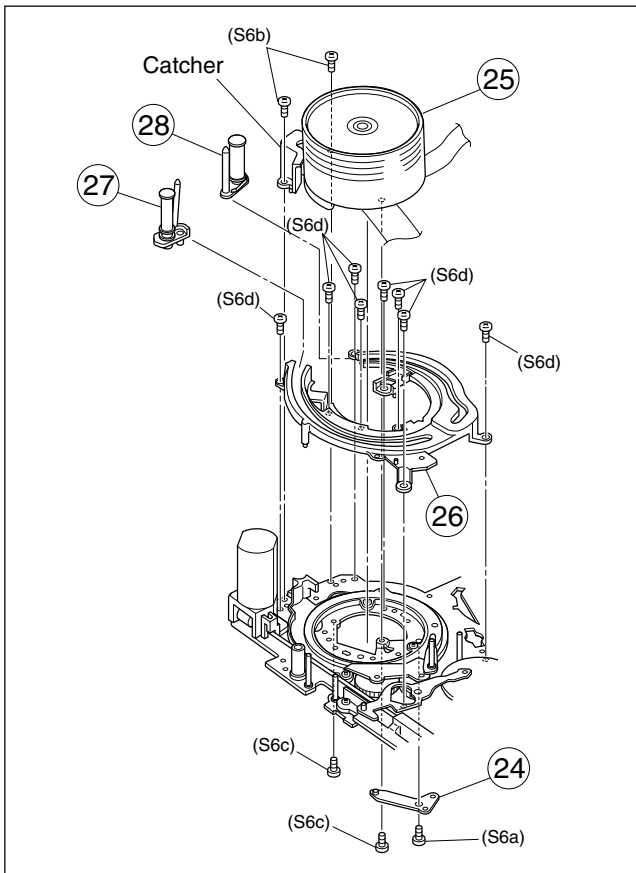

Fig. M6

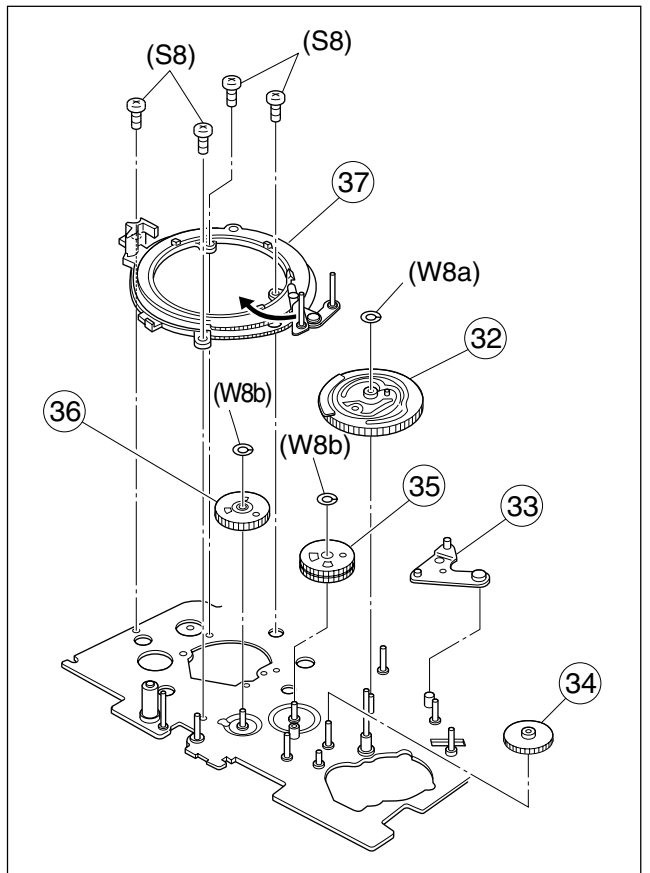

Fig. M8

2.3 CHECKUP AND ADJUSTMENT OF MECHANISM PHASE

Note: Pay careful attention to the installing order and phase of mechanism parts of the loading system.

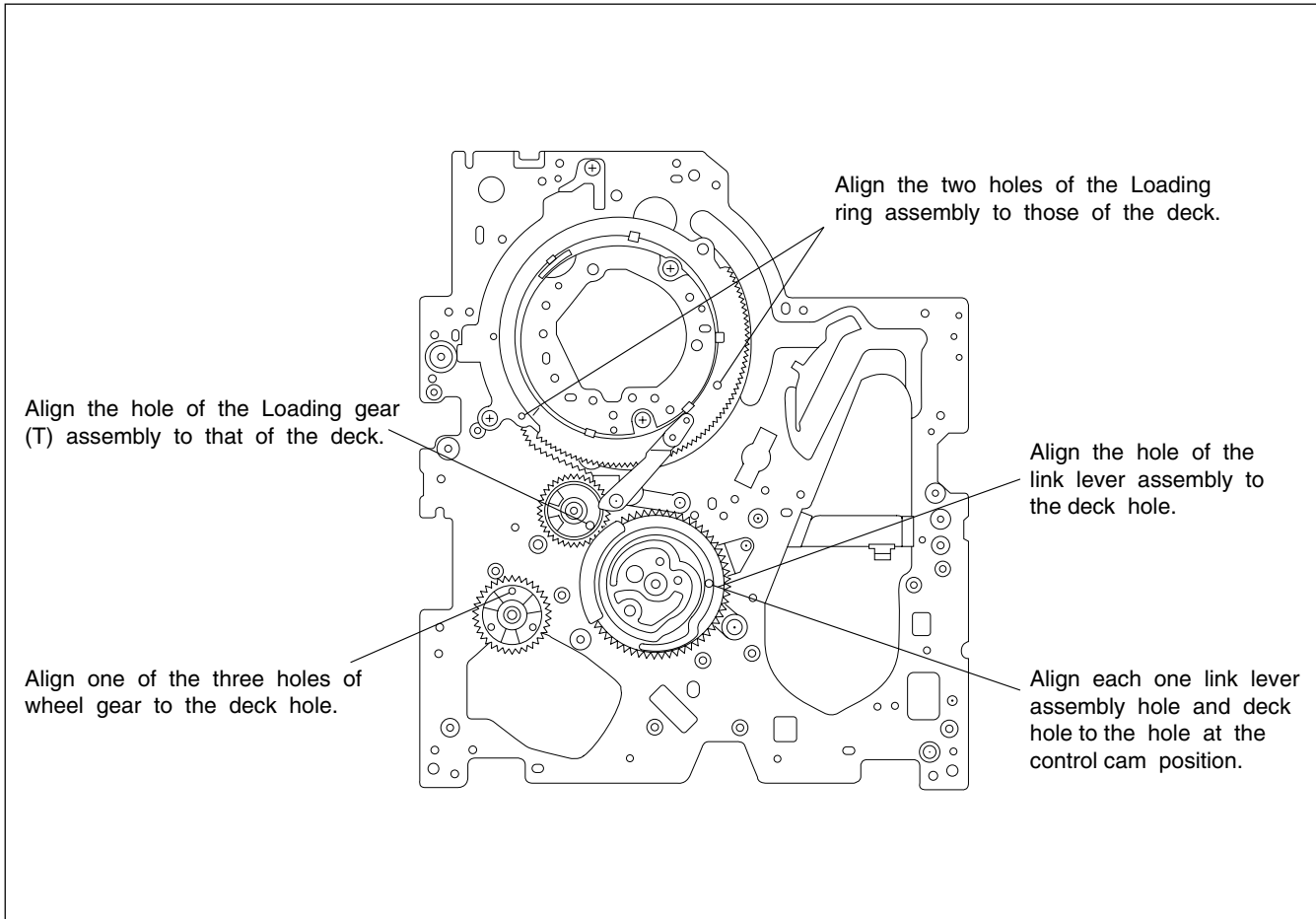

Fig. 2-3-1 Top of main deck

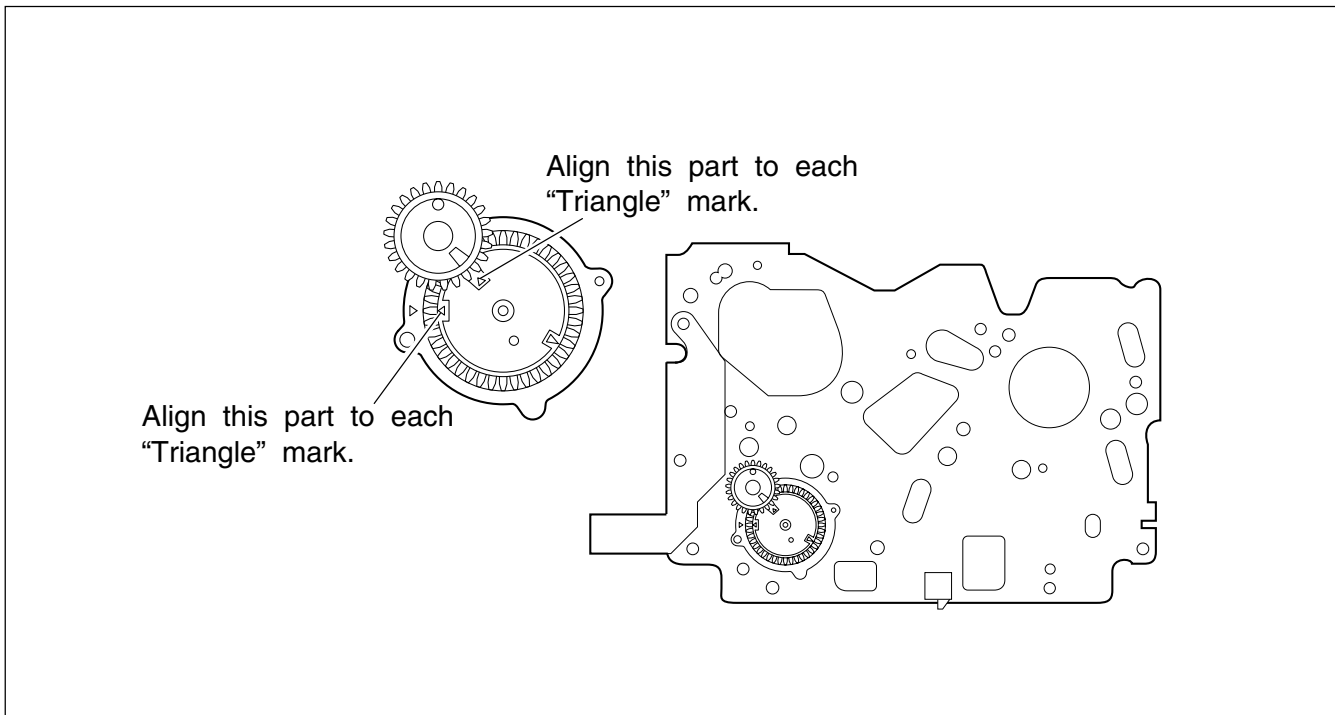

Fig. 2-3-2 Rotary encoder

2.4 TAPE TRANSPORT ADJUSTMENT

In most cases the deck section is in need electrical adjustment, it results from replacement of worm mechanical parts or video heads. In the event of malfunction with electrical circuits, troubleshooting with the aid of proper test instruments must be done first, and then commence necessary repair, replacement and adjustment, etc.

2.4.1 Back tension

1. Set a cassette torque meter onto the deck and measure the back tension in standard REC mode to confirm that the back tension is $0.7 \times 10^{-3} - 1.37 \times 10^{-3} \text{ N}\cdot\text{m}$.
2. If not, replace the tension band.
When the value widely fluctuates in the measurement, replace the supply reel disk.
3. With the cassette torque meter, confirm that the play torque is $1.47 \times 10^{-3} - 2.45 \times 10^{-3} \text{ N}\cdot\text{m}$.
If necessary, replace the center pully unit.

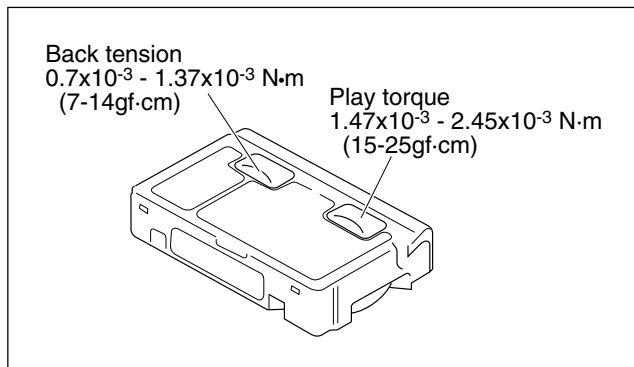

Fig. 2-4-1 Cassette torque meter

2.4.2 Tape pattern

1. Remove the Cover (JIG) shown on Fig. 2-6-1 (Page 2-10).
2. Connect the jig connector cable to CN25 on the MAIN board as shown on Fig. 2-6-1 (Page 2-10).
3. Observe signal at V. TP FM with external trigger from V. FF on the jig connector cable.
4. Playback the SP stairstep signal of the alignment tape and maximize the FM waveform by the tracking button.
5. Set the tracking control to the center position by simultaneously pressing the tracking (-) and (+) buttons and maximize the FM waveform by the tracking button.
6. If the observed FM waveform is not flat, adjust the height of the supply of take-up guide roller with the roller driver.

Note: To prevent the tape from damage, turn the guide rollers slowly.

7. By operating the tracking button (both in + and - directions) in the manual tracking mode, vary the output level of the FM waveform from maximum to minimum and vice versa to confirm that the waveform varies nearly in a flat shape.

8. When the FM waveform breaks in the level varying process, subtly adjust the height of guide rollers at every breaking point so that the waveform varies as flat as possible.
Repeat the above steps 6. and 7. several times to confirm that the waveform is flat as a whole.
9. Playback the SP stairstep signal of alignment tape and adjust the tracking control to maximize the FM waveform, confirm that FM waveform variation is always flat.
10. Record the signal and play it back in both of the SP and LP modes, and confirm that the FM waveform is flat in both modes.

Note: Among the above-mentioned adjustment steps, the items of No.9 and No.10 are needed for the LP model only.

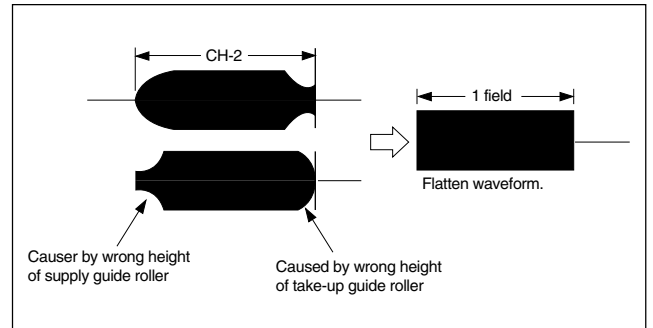

Fig. 2-4-2 FM waveform-1

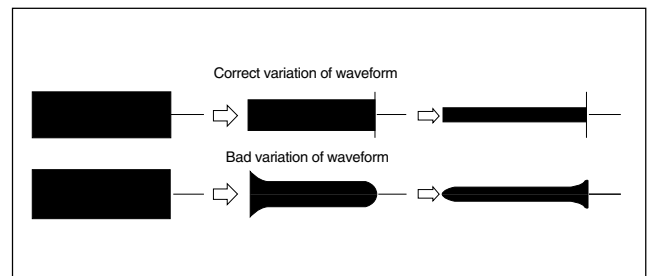

Fig. 2-4-3 FM waveform-2

(P)

11. Through the above steps, confirm that there occur no wrinkling and damage in the tape around the pinch roller and TU guide pole whenever the deck is in operation of Loading/Unloading, Search Rewind and at mode change from Search Rewind to play mode. If wrinkling or damage in the tape occurs around the TU guide pole, adjust the angle (slant) of the A/C head to the tape. So that the tape normally runs along the lower flange of the guide pole.

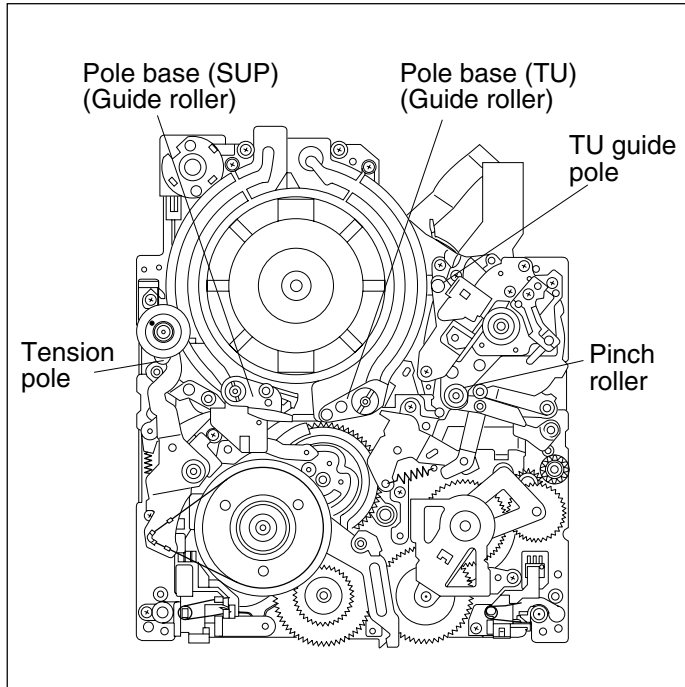

Fig. 2-4-4 Tape transport system

2.4.3 A/C head height & azimuth

1. Connect the jig connector cable to CN25 on the MAIN board.
2. Connect the channel-1 scope probe to the audio output and connect the channel-2 scope probe to PB CTL.
3. Playback the alignment tape.
4. Set the tracking to its center range by pressing the (+) and (-) tracking controls simultaneously.
5. Adjust screws (A), (B) and (C) approximately 45 degrees in the same direction to obtain maximum audio output and CTL signal levels.
6. As a final fine adjustment, adjust screw (B) for minimum signal level fluctuation and screw (C) for maximum output signal level.

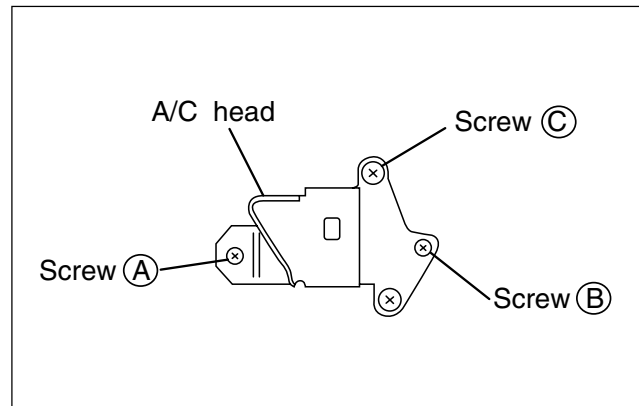

Fig. 2-4-5 A/C head

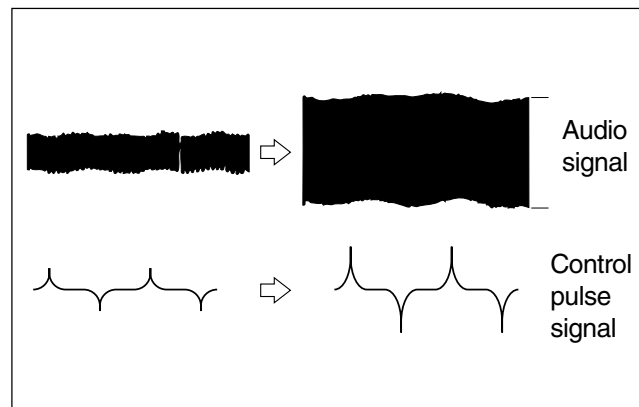

Fig. 2-4-6 Audio and CTL signal

2.4.4 Phase of control head (X value)

1. Connect the jig connector cable to CN25 on the MAIN board.
2. Playback the SP stairstep signal of the alignment tape and observe signal at V.TP FM with external trigger from V.FF on the jig connector cable.
3. Operate the tracking button in the center and manual tracking mode by pressing the tracking (+) and (-) buttons and confirm that the FM output level is maximum at the center position as shown in Fig. 2-4-8.
4. If necessary, slightly loosen the setscrews ④ and ⑤ and insert the Tweezers into the notch and guide hole to move the A/C head fully in the direction of the capstan to the extent.
5. Gradually move the A/C head toward the drum to find the position where the FM output level maximum for the first time (a' - b' in Fig. 2-4-8).
6. Fine adjust the phase of the A/C head and tighten the screws ④ and ⑤ at the point a.

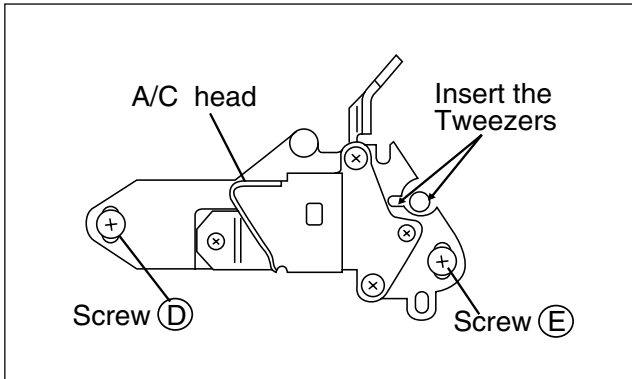

Fig. 2-4-7 Phase of control head

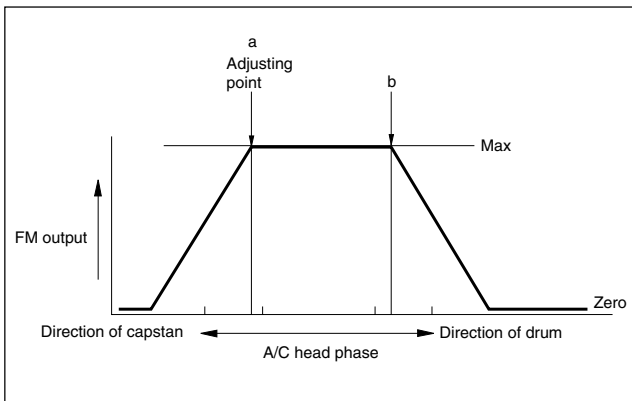

Fig. 2-4-8 Phase adjustment point of control head

2.5 REMARKS

2.5.1 Cleaning

1. For cleaning of the upper drum (particularly video heads), use fine-woven cotton cloth or Kimwipe with alcohol soaks through. Do not move the cloth but turn the upper drum counterclockwise.
Note: Make sure not to move the cloth in the vertical direction to the video head, since it may cause damage of the video heads.
2. For cleaning of parts of the tape transport system except the upper drum, use fine-woven cotton cloth or cotton swab soaked alcohol.
3. After cleaning, confirm that the cleaned parts are completely dry before loading the deck with cassette tape.

2.5.2 Applying oil and grease

1. Periodical oiling and greasing are not required but should be done to new parts when replacing. If oil and grease on the other parts of the other party are old and dirty, wipe them clean and apply new oil or grease.
2. For parts and points to apply oil and grease, refer to the exploded view of the mechanism assembly (M3). Table 2-5-1 specifies oil and grease to be used.
3. When oiling, clean the objective parts with alcohol first and apply one or two drop(s) of oil. Too much oiling causes rotary parts to slip because of oil leakage.

Classification	Name	Symbol in drawing
Grease	KYODO-SH-P	AA
Oil	YTU94027	BB

Table 2-5-1 Specific oil and grease to be used

2.5.3 Checkup

After replacement of the supply reel disk and tension band, make sure to inspect back tension according to the adjustment procedure of MECHANISM ADJUSTMENT section.

2.6 JIG CONNECTOR CABLE CONNECTION

Remove the cover (JIG).

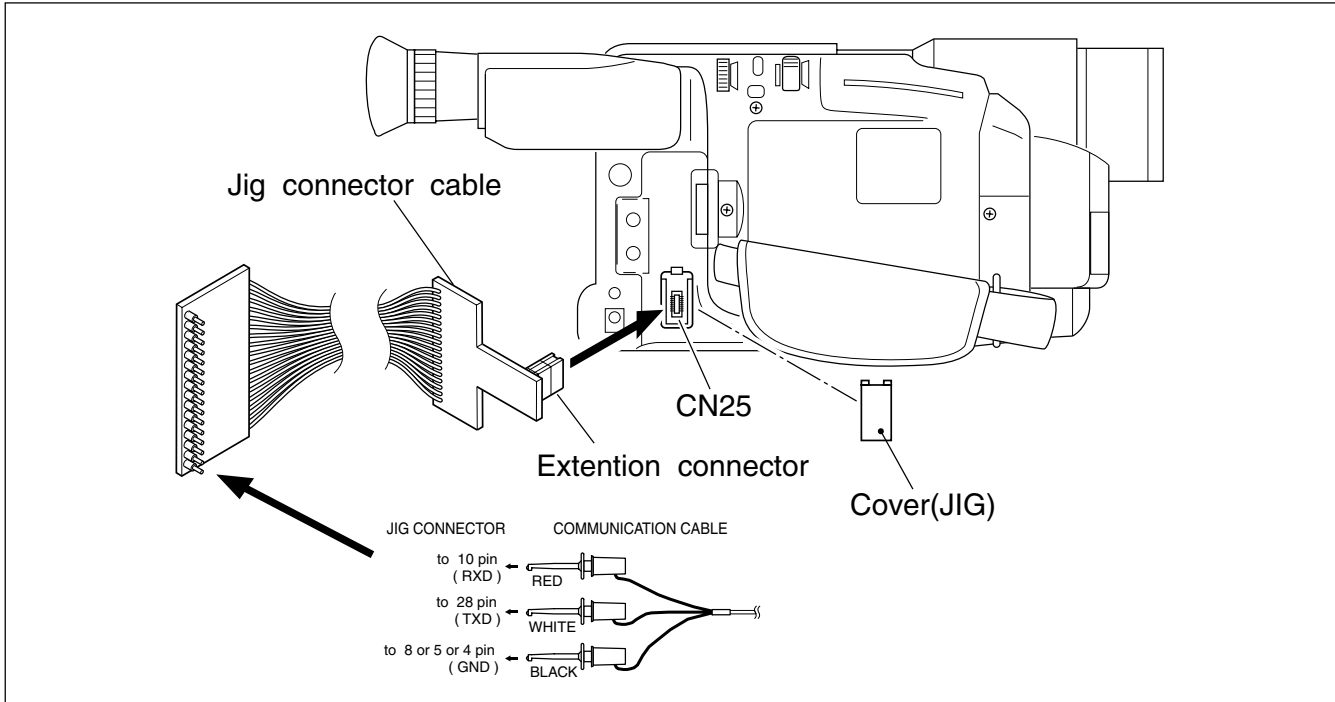

Fig. 2-6-1 Jig connector cable connection

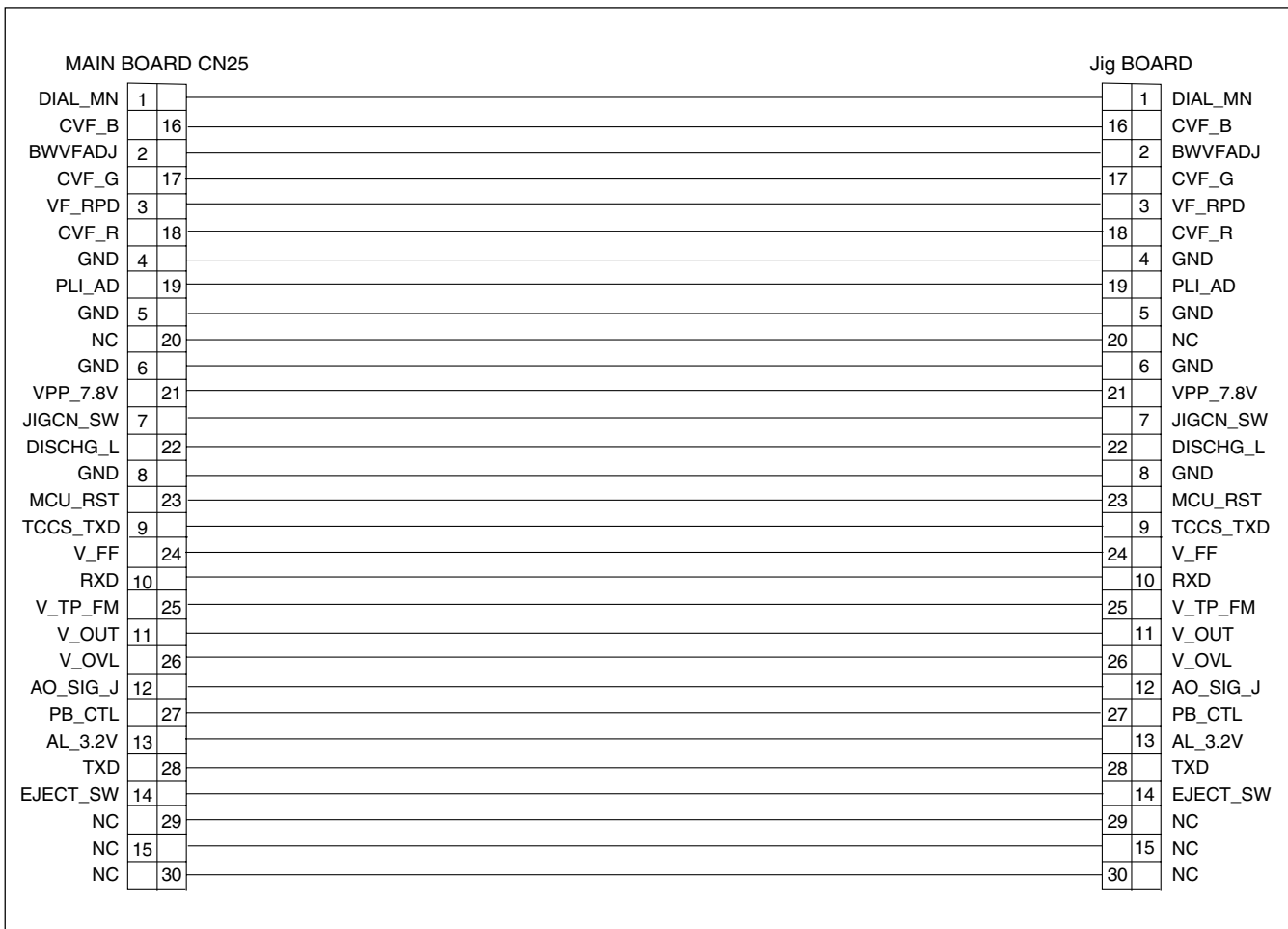

Fig. 2-6-2 Jig connector cable schematic diagram

SECTION 3 ELECTRICAL ADJUSTMENT

3.1 ELECTRICAL ADJUSTMENT

3.1.1 PREPARATION

1. Precaution

This model does not contain adjustment controls (VR). General deck system, camera system and monitor system adjustment are not required. However, if MAIN board and MONITOR board need replacement, please use original E 2 PROM on to new board. Then adjustment are not required. And if parts such as the following need replacement, special computerized adjustment are required (Refer to sec. 3.1.1- 4). Please contact to JVC Service for detaile information.

- OP block
- EEP ROM (IC102 of MAIN board)
- MONITOR

In the event of malfunction with electrical circuits, trouble-shooting with the aid of proper test instruments must be done first, and then commence necessary repair, replacement and adjustment, etc.

1. In case of wiring to chip test points for measurement, use IC clips, etc. to avoid any stress.
2. Since connectors are fragile, carefully handle them in disconnecting and connecting.
3. Shortcircuit between operation un it and DECK chassis.

2. Required test equipment

1. Color TV monitor.
2. AC power adapter
3. Oscilloscope (dual-trace type, observable 100 MHz or higher frequency)
 - * It is recommended to use one observable 300 MHz or higher frequency.
4. Digital voltmeter
5. Frequency counter (with threshold level adjuster)
6. Personal computer

3. Required adjustment tools

For details of special jigs necessary for adjustment, refer to page 1-2 and 1-3 of the Section 1.

4. Setup for E. VF section adjustment

Referring to "SEC. 1 DISASSEMBLY" and connect the E. VF WIRE to CN12 of the MAIN board.

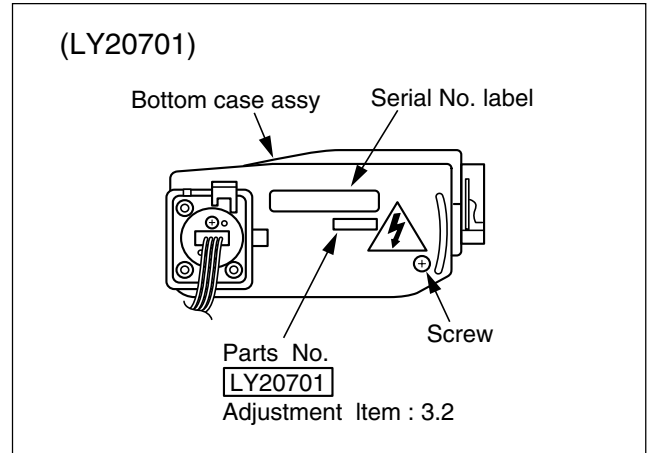

Note:

- This adjustment falls into a special adjustment that requires a personal computer. For details, refer to "3.1.1 Preparation".

5. Connection for Service support system

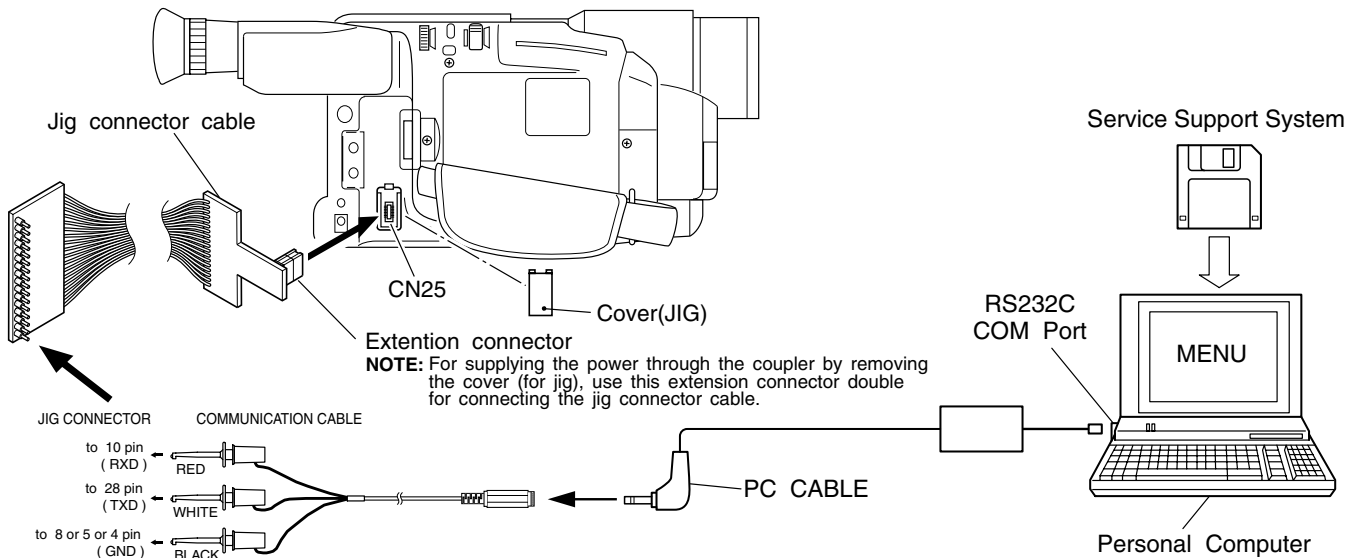

Fig. 3-1-1 Connection for Service support system

3.2 ELECTRONIC VIEWFINDER (E. VF) ADJUSTMENT

Notes:

- Unless otherwise specified, all measurement points and adjustment parts are located on E. VF board.
- After adjustment or replacement of the deflection yoke or the centering magnet, fix it by the band as shown the figure below.

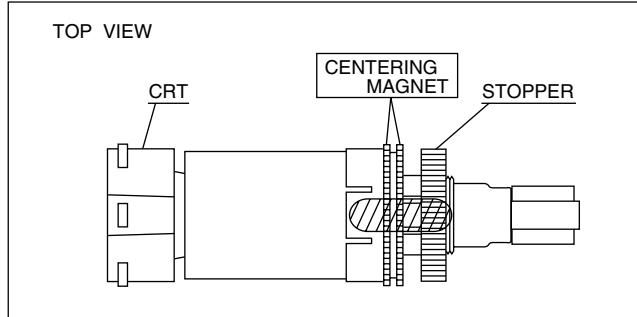

Fig. 3-2-1 E. VF

- After adjustment is completed, compare the picture on the E. VF screen with the monitor TV.

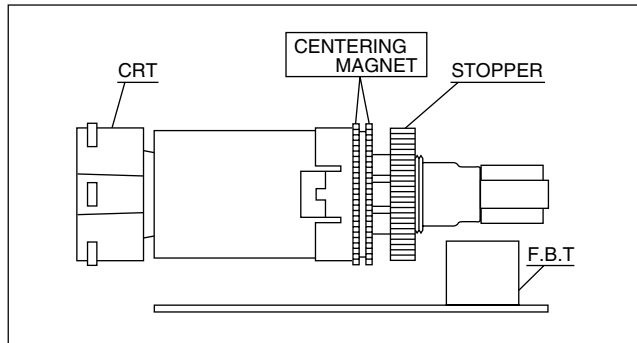

Fig. 3-2-2 E. VF

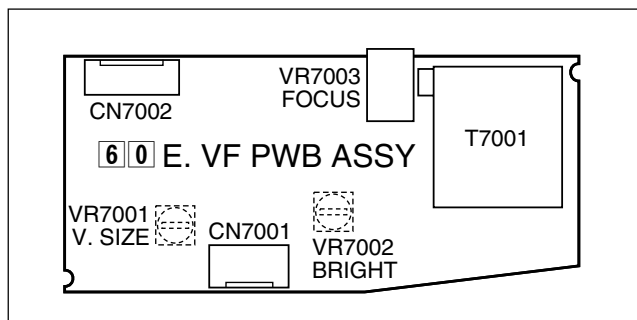

Fig. 3-2-3 E. VF board

3.2.1 Tilt

Subject	• Alignment tape • Stairstep
Mode	• PB
Equipment	• E. VF
Measurement point	• E. VF screen
Adjusting part	• Deflection yoke
Specification	• The picture is visible as same as monitor TV.

- 1) Put the deflection yoke to the most inner side of CRT neck first. Then fix the stopper temporary.
- 2) Adjust the tilt of picture on the E. VF screen by tilting the deflection yoke.
- 3) Fix the stopper completely.

3.2.2 Centering

Subject	• Alignment tape • Stairstep
Mode	• PB
Equipment	• E. VF
Measurement point	• E. VF screen
Adjusting part	• Centering magnet (CRT assy)
Specification	• The center of the E. VF screen

- 1) While observing the viewfinder screen, adjust the centering magnet to locate the stairstep in the center of the view-finder screen.

3.2.3 Vertical scanning

Subject	• Camera picture
Mode	• EE
Equipment	• E. VF
Measurement point	• E. VF screen
Adjusting part	• VR7001 (V. SIZE)
Specification	• Normal picture amplitude

- 1) Observing the viewfinder screen, adjust VR7001 for normal picture amplitude.

3.2.4 Brightness

Subject	• --
Mode	• EE • Lens closed
Equipment	• E. VF
Measurement point	• E. VF screen
Adjusting part	• VR7002 (BRIGHT)
Specification	• The CRT raster is just barely visible

- 1) Close the lens with the cap and adjust VR7002 so that the raster of the CRT is just visible in the E. VF.

3.2.5 Focus

Subject	• Camera picture
Mode	• EE
Equipment	• E. VF
Measurement point	• E. VF screen
Adjusting part	• VR7003 (FOCUS)
Specification	• The center area is clear and defined

- 1) While observing the viewfinder screen, adjust VR7003 so that the picture at the central area of the screen is clear and defined.